

Background ventilators for dwellings

IP 2/03

D I Ross, R K Stephen and J B M Pierce

BRE Environment

Trickle vents in window frames and airbricks in walls have been used to ventilate dwellings for many decades. However, the concept of background ventilation as part of an overall ventilation strategy did not appear in Approved Document F of the Building Regulations until 1990.

Initially, only simple manually adjustable background vents were used in the UK to meet these regulations, but more innovative vents incorporating automatic flow control or other novel features are now appearing on the market.

This paper discusses the philosophy behind background ventilation in Building Regulations, the types and merits of background vents currently available, and a method of vent performance testing proposed in a forthcoming European Standard.

What is a background vent?

In simple terms, a background ventilator is simply a hole between a room space and the outside to provide a route for a nominally continuous exchange of ventilation air. Typically they take the form of either a 'trickle ventilator' fitted into a window or an 'airbrick' fitted through a wall in a dwelling, and have a free area of about 8000 mm² or less.

They provide a general background level of ventilation to provide fresh air to the occupants and to dilute generally spread pollutants. They are not intended to deal with locally high pollutant production (including water vapour) such as occurs with cooking or bathing. Rather, they are intended to deal with any pollutants (including water vapour, chemicals and bio-organisms) which are released at relatively low rates from sources distributed all over the dwelling, and residual pollutants which are not removed by other means and then become well distributed. However, background vents do also contribute make-up air to extract fans in kitchens and bathrooms.

Background vents and the Building Regulations

Building Regulations and Standards in Northern Ireland and Scotland have adopted an approach to domestic ventilation which is similar to that taken in England and Wales. Therefore this paper concentrates on the England and Wales Regulations.

The concept of background ventilation was introduced into Approved Document F of the Building Regulations for England and Wales^[1]

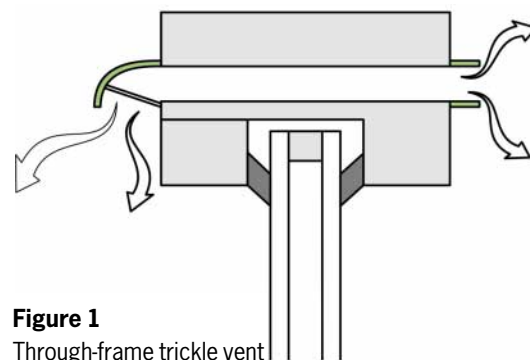

Figure 1
Through-frame trickle vent

in 1990 as part of an overall strategy for ventilating a dwelling. This strategy comprises three components:

- Openable windows to provide ‘rapid ventilation’ (to dilute occasionally local concentrated pollutants, such as smoke from burnt food during cooking, or volatile solvents from paints during redecorating)
- Extract fans or passive stack vents to provide ‘extract ventilation’ (to remove water vapour and other locally produced pollutants from their source rooms, such as odours in WCs and water vapour in bathrooms and kitchens)
- Trickle vents or airbricks to provide ‘background ventilation’

The role of background ventilation as defined in current Building Regulations^[2] is to ‘make available over long periods a minimum supply of fresh air for occupants and to disperse, where necessary, residual water vapour. Such ventilation should not significantly affect comfort and, where necessary, should be reasonably secure and provide protection against rain penetration’. Thus, background vents provide a nominally constant level of ventilation throughout the dwelling to dilute to

an acceptable level those pollutants which are not removed by other means (ie by local extract and rapid ventilation).

In reality, background ventilation is provided by a combination of purpose-provided background vents and air leakage through the dwelling structure (see IP1/00 for details of air leakage in UK dwellings). Ideally the size of background vents required would depend upon how airtight the dwelling was – but airtightness is not normally known, so a fail-safe approach is taken in Building Regulations whereby background vents are sized on the assumption that the dwelling may be very airtight.

Approved Document F recommends that background vents are manually adjustable so that they can be opened and closed as required by the occupants according to the dwelling’s airtightness (through perceived air quality) and to avoid draughts in windy weather. It also recommends that the vents are located at high level (typically at least 1.75 m above floor level) in order to reduce the risk of draughts affecting sedentary occupants in the room.

It should be noted that Approved Document F specifies background vent sizes in terms of ‘free area’. It would have been preferable to specify vent sizes in terms of ‘equivalent area’ (see box, left, for definitions) but that was not possible because of the absence of a standard test method in 1995. Future editions of Approved Document F may adopt equivalent area following publication of the proposed European Standard for testing of background ventilators^[3] (see box on page 6).

It is worth remembering that even where they are not required by Building Regulations, it is always wise to include background ventilators when old leaky windows are replaced with new (more airtight) draughtstripped windows. This will help to ensure that adequate ventilation can be maintained.

Free area or equivalent area?

The current (1995) edition of Approved Document F^[2] specifies ventilation openings in terms of a ‘free area’ (also often referred to as ‘open area’ and ‘free air space’). Future editions of Approved Document F may switch to using an ‘equivalent area’ following publication of the proposed European Standard for testing background ventilators^[3]. So what do the terms ‘free area’ and ‘equivalent area’ mean?

Free area is simply the physical size of the smallest aperture in a ventilator. For an ordinary grille with many holes, the free area is the sum of the areas of all the individual holes. If a ventilator has an internal and an external grille linked by a cavity sleeve, the free area applies to whichever grille (or any blockage in the cavity sleeve) has the smallest area of hole(s). But this has a problem: whilst it is relatively easy to calculate, it does not necessarily reflect the airflow performance which the vent will achieve. The more complicated or contorted the airflow passages in a ventilator, the less air will flow through for a given pressure difference. So two different vents with the same free area will not necessarily have the same airflow performance.

Equivalent area is a better measure of airflow performance (‘effective area’ is often used to mean the same thing — as in the Noise Insulation Regulations^[4]). The equivalent area of a ventilator is measured on an airflow test rig; it is defined as the area of a single sharp-edged hole (in a thin plate) that passes the same air volume flow rate and at the same applied pressure difference as the vent being tested. Most airbricks and trickle vents with the same equivalent area will have similar airflow performance even though they may not have the same free area.

Equivalent area is a convenient means of specifying the required performance of vents in Building Regulations because, unlike free area, it reflects the actual aerodynamic performance of the vent and is relatively insensitive to pressure difference for fixed and manually adjustable ventilators. However, for self-regulating ventilators more considered specification of performance will be required, perhaps based on equivalent area at a particular pressure difference and/or the shape of the flow/pressure characteristic curve. For that reason it is useful to present test results graphically as well as an equivalent area value.

Review of available background ventilators

Manually adjustable vents

These are simple passages to the outside with some form of flap or slider which occupants may operate to open and close, or adjust, the ventilator passages (Figure 1). They are the type of vent most commonly employed to meet the recommendations for background ventilation in Approved Document F.

Window-mounted vents are the most widely used types, usually referred to as trickle vents. They come in three main forms:

- Mounted over or in a slot routed into the top of a window frame section ('through-frame'; Figure 1)
- Designed to fit into the top of the glazing rebate occupying the top few centimetres of glazing ('glazed-in'; Figure 2)
- Designed to fit on top of the window frame and occupying the full width of the window frame ('over-frame'; Figure 3)

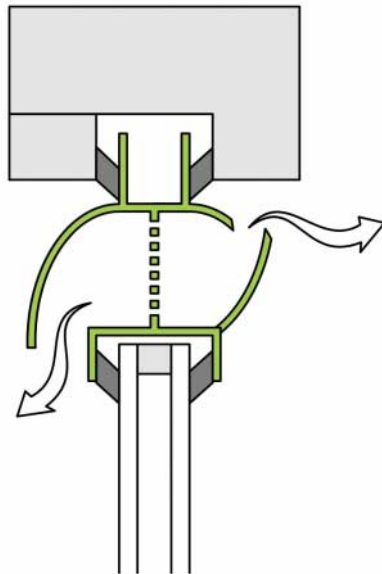

Figure 2 Glazed-in ventilator

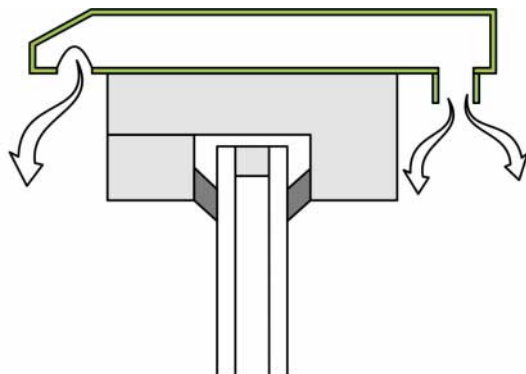

Figure 3 Over-frame type of window-mounted vent

Window-mounted vents are available to fit timber, PVC-U, metal or composite framed windows.

A few wall-mounted manually adjustable vents are available. They generally comprise an ordinary airbrick type vent with a hit-and-miss closable internal louvre or grille in place of the usual permanently open type.

Humidity-controlled vents

Several manufacturers supply self-regulating background ventilators which respond to the level of relative humidity inside the room. They are available in either through-frame or wall-mounted types. The vents are passive in operation, not requiring any form of electrical power to work.

Typically these vents are in the fully open position at a relative humidity of 70% or above and progressively close down until fully closed at a relative humidity of around 35%. They can be provided with a manual open and close override such that they may comply with Approved Document F.

Humidity-controlled vents are intended to regulate background ventilation rates according to indoor humidity levels, on the assumption that other pollutants are also adequately controlled. However, the assumption may not be valid in households with low humidity levels where the ventilators may be partially or fully closed and other pollutants, such as chemicals and bio-organisms, are then not so effectively removed.

Temperature-controlled vents

Several temperature-controlled vents are available, although they are generally intended to reduce draught risks in cold climates when used as make-up air vents for mechanical extract ventilation systems. However, such vents might also be employed as background ventilators.

These ventilators regulate the airflow by means of a thermostatic device according to the temperature of the air passing through the vent. The typical range for regulating airflow is from about -4°C (fully closed) to $+20^{\circ}\text{C}$ (fully open).

Note that on a cold winter's day current designs of ventilator may remain fully open if the airflow is from inside to outside, whilst they may close down if the airflow happens to be from outside to inside. Thus the vent does not necessarily respond to the level of ventilation required inside the dwelling and is not really suited to use in providing background ventilation. Manual override is essential.

Pressure-difference-controlled vents

Pressure-difference-controlled background vents (Figure 4) are used in France and the Benelux countries and, more recently, in the UK. The French types are generally simple (but effective) plastic moulded types which are very similar in size and appearance to the window-mounted trickle vents popular in the UK. They typically employ a thin plastic strip or membrane which distorts progressively under increasing pressure difference to reduce the area of the vent opening. French Regulations and Standards effectively define the operating performance of these vents such that they behave like ordinary trickle vents up to about 20 Pa, the airflow then rising only slowly with increasing pressure difference up to about 100 Pa.

The types originating from the Benelux countries are generally larger and more robustly engineered, employing aluminium and plastic extrusions in their construction. They typically employ a vertically hung flap which swings progressively under increasing pressure difference to reduce the area of the vent opening. The flap is usually either a freely hinged rigid extrusion which swings under gravity or a plastic co-extrusion incorporating a flexible hinge portion. These vents regulate the flow at lower pressures than the French types, typically starting at 8 to 10 Pa.

In both cases the great benefit of these pressure-difference-controlled self-regulating vents is their ability to reduce the risks of over-ventilation and annoying draughts in windy weather. Draughts are a major reason for occupants closing background vents and, once closed, a background vent is likely to remain closed. Thus, when correctly maintained, pressure-difference-controlled background vents have potential to relieve the occupants of the need to close them in windy weather whilst maintaining adequate but not excessive levels of ventilation in most weather conditions.

Both types of ventilators are useful in the UK, as they reduce the risks of over-ventilation

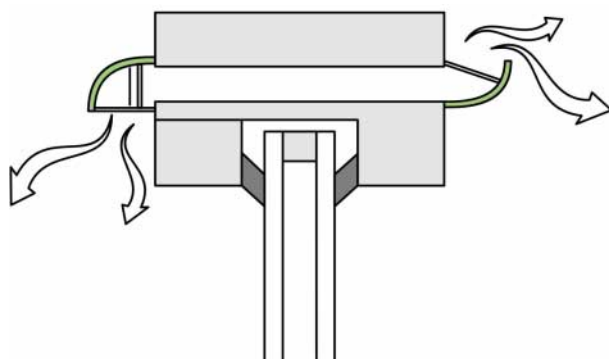

Figure 4 Pressure-difference-controlled vent

and annoying draughts in windy weather. It is hoped that future generations of pressure-difference-controlled ventilators will start regulating at more typical pressures (eg 1 Pa), in an attempt to provide an approximately constant supply of ventilation which is relatively independent of outdoor wind conditions.

It should be noted that all pressure-difference-controlled vents currently on the market will only control airflow from outside to inside the dwelling. In the opposite flow direction the vents all remain fully open and behave as ordinary fixed vents unless manually closed by the occupants.

Acoustic vents

Acoustic vents (Figure 5) are likely to play an increasing role in providing background ventilation because noise entering a room through windows or vents is perceived to be a major obstacle to the implementation of natural ventilation in urban areas. This is particularly so close to busy roads, railways and airports. However, the term 'acoustic vent' is not well defined in literature and care must be taken when considering the performance based on manufacturers' descriptions alone. For example, an 'acoustic ventilator' from one manufacturer may not necessarily give a significantly better acoustic performance than a non-acoustic ventilator from another.

Acoustic vents (discussed more fully in IP4/99) are characterised by having improved sound attenuating properties, when open, over normal types of vent. The acoustic performance of any ventilator is compromised when it is open and will vary with the free area. However, this can be mitigated to some extent by specialist design. Improved sound attenuation is mainly achieved by adding sound-absorbent linings to internal surfaces of the flow passage(s) and sometimes also by designing contorted flow passages.

The sound-attenuating performance of ordinary background vents may be improved to some extent by fitting an external 'acoustic canopy' in place of the standard item. However, their acoustic performance may be little better than the standard vent and will fall far short of that obtained by a purpose-made acoustic ventilator.

A few purpose-designed manually adjustable acoustic vents suitable for background ventilation are already available from several manufacturers. Vents with good acoustic performance are much more bulky than ordinary background vents and so a higher proportion are through-the-wall type vents.

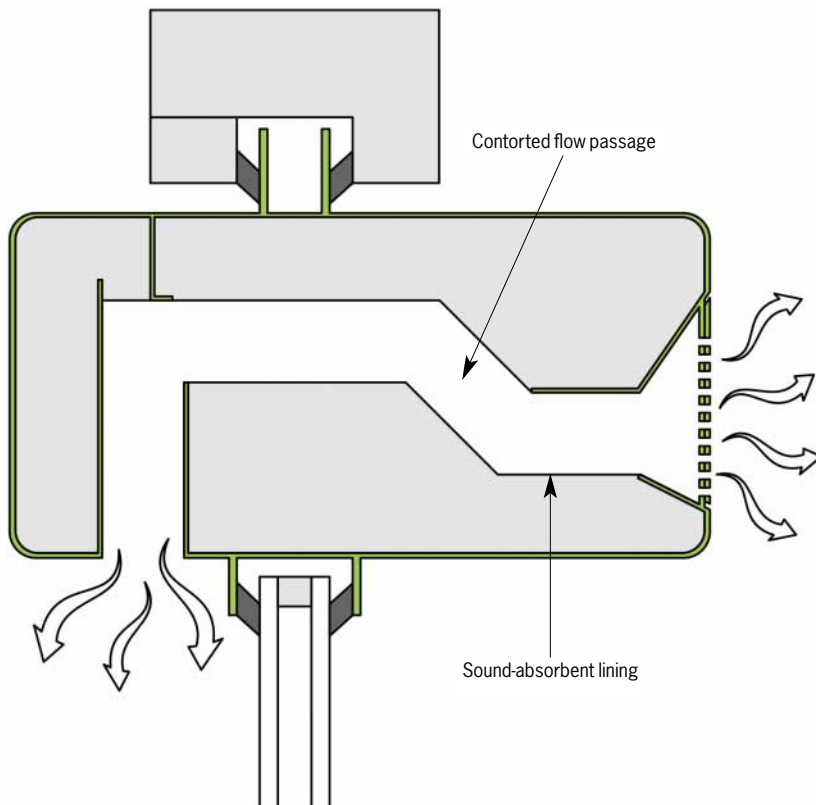

Figure 5 Acoustic vent

However, a number of glazed-in and over-frame type window-mounted vents are available (mainly from the Benelux countries), the latter potentially avoiding the problem of reduced window glass area in new build applications. At least one manufacturer has developed a pressure-difference-controlled self-regulating acoustic vent for over-frame fitting.

Choice of background ventilator

For most situations – ie low-rise dwellings away from noisy areas – ordinary manually adjustable background ventilators such as trickle vents will normally be adequate for ventilation, acceptable to the occupants and economic to the builder and landlord. However, more care may be needed in selecting background vents for other situations.

Dwellings in the upper floors of high-rise blocks and low-rise dwellings in exposed locations, such as on exposed hillside and coastal sites, have higher exposure to weather which may result in annoying draughts from background vents and, perhaps, over-ventilation and energy waste. Pressure-difference-controlled self-regulating

background vents are an attractive solution in such situations to mitigate draughts whilst maintaining adequate ventilation in calmer weather. In such situations it is also wise to ensure that the dwelling structure is reasonably airtight.

In noisy areas occupants may keep ordinary background vents permanently closed to reduce nuisance from external noise. Typical examples of such areas are close to main roads, railways and airports, but dwellings close to industrial sites may also be badly affected. The preferred solution is to install well designed purpose-made acoustic ventilators. If the dwellings involved have existing single-glazed windows then window-mounted acoustic vents in replacement double-glazed windows may be an attractive package.

Where high-rise or exposed dwellings are also located in a noisy area there are few background ventilation products currently available that will help. The ideal would be to use a properly designed pressure-difference-controlled acoustic ventilator but we are aware of only one such vent on the European market at present. A reasonable compromise would be to use manually adjustable acoustic vents which the occupants can close in windy weather.

Retro-fitting background vents in listed buildings can be difficult, modern plastic and aluminium vents being out of keeping with the architectural features of period buildings. Solutions will have to be found through negotiation with the relevant local authority. If replacement reproduction windows are to be fitted then use of over-frame type background vents may be acceptably unobtrusive and will avoid puncturing the existing style of window frames with ordinary trickle vents. Alternatively, vents may be discretely hidden by minor modifications to wooden window frame profiles. If the existing windows have to be retained or over-frame vents cannot be used, it may be possible to adapt existing airbricks or other openings for use as background vents. UK manufacturers are developing better solutions for ventilation in listed buildings.

References

- [1] **Department of the Environment and the Welsh Office.** *The Building Regulations 1985 Approved Document F1. Means of ventilation* (1990 edition). London, HMSO, 1989.
- [2] **Department of the Environment and the Welsh Office.** *The Building Regulations 1991 Approved Document F1. Means of ventilation* (1995 edition). London, HMSO, 1994.
- [3] **European Standards Committee (CEN).** Ventilation for buildings – Performance testing of components/products for residential ventilation. Part 1: Externally and internally mounted air transfer devices. prEN 13141-1. CEN, Brussels, February 1998.
- [4] **The Noise Insulation Regulations 1975** (as amended 1988). *Statutory Instrument No 1763*. London, HMSO, 1975.

BRE Information Papers

IP1/00 Airtightness in UK dwellings

IP4/99 Ventilators: ventilation and acoustic effectiveness

Forthcoming European CEN Standard prEN 13141-1^[3] on performance testing

This standard covers the performance testing of background ventilators for their aerodynamic characteristics, sound insulation and watertightness. Its scope includes ordinary vents and self-regulating vents which respond to the stimulus of pressure difference. Neither humidity- nor temperature-controlled self-regulating vents are covered. At the time of writing, the standard is not in force but the draft has been approved by the technical committee (CEN/TC156) to go forward for formal vote.

The aerodynamic testing includes determination of the flow rate/pressure characteristics of the vent and the equivalent area. The flow rate/pressure tests are carried out in an experimental rig which determines the volume flow rate through the vent for an applied static pressure difference across it. Details of the design of a rig are provided in the standard. As an example, BRE's rig is shown in Figure 6.

For ordinary vents, the flow rates are measured at a number of set pressure differences defined in the standard. The measurements are then corrected to standard barometric pressure and temperature conditions before further analysis. The results are plotted graphically and, where appropriate, a curve is fitted to the points by linear regression. The airflow rate at any pressure difference in the measured range can then be calculated from the equation of that curve.

For self-regulating types, where the airflow through the ventilator always increases with increasing applied pressure difference, the test can be carried out in the same way as for ordinary ventilators. However, the results are simply presented graphically as it is not appropriate to fit a curve to the test results. However, some vents have a characteristic where airflow rate decreases with increasing pressure difference over part of the performance curve. Measurements may not be able to be made over certain pressure ranges and this should be noted in the results. There is an alternative method that BRE has developed for measuring such vents, but it is not included in the standard.

The equivalent area of the vents can be simply determined from the flow/pressure data collected. For ordinary ventilators, the equivalent area should be relatively independent of the pressure difference. For self-regulating ventilators, the equivalent area will vary with the pressure difference applied. It is possible that future editions of Approved Document F^[2] will specify natural ventilation provisions in terms of equivalent areas at specific pressure differences using the test method in this CEN standard.

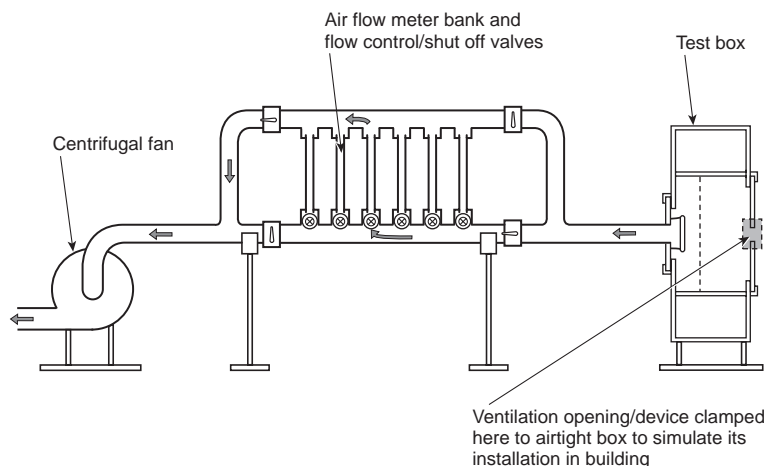

Figure 6 The BRE test rig



www.bre.co.uk

BRE is committed to providing impartial and authoritative information on all aspects of the built environment for clients, designers, contractors, engineers, manufacturers, occupants, etc. We make every effort to ensure the accuracy and quality of information and guidance when it is first published. However, we can take no responsibility for the subsequent use of this information, nor for any errors or omissions it may contain.

BRE is the UK's leading centre of expertise on building and construction, and the prevention and control of fire. Contact BRE for information about its services, or for technical advice, at: BRE, Garston, Watford WD25 9XX
Tel: 01923 664000
Fax: 01923 664098
email: enquiries@bre.co.uk
Website: www.bre.co.uk

Details of BRE publications are available from BRE Bookshop or the BRE website. Published by BRE Bookshop, 151 Rosebery Avenue, London EC1R 4GB
Tel: 020 7505 6622
Fax: 020 7505 6606
email: brebookshop@emap.com

Requests to copy any part of this publication should be made to: BRE Bookshop, Building Research Establishment, Watford, Herts WD25 9XX
© Copyright BRE 2003
February 2003
ISBN 1 86081 610 X