

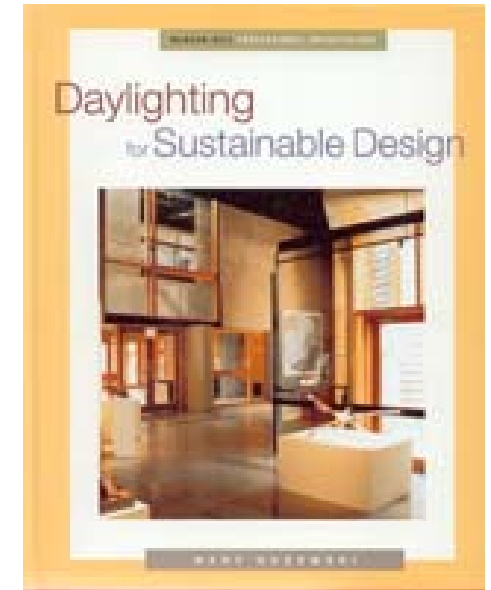

Arch 226: Environmental Building Design
Daylighting Concepts

Primary references and image sources for this presentation

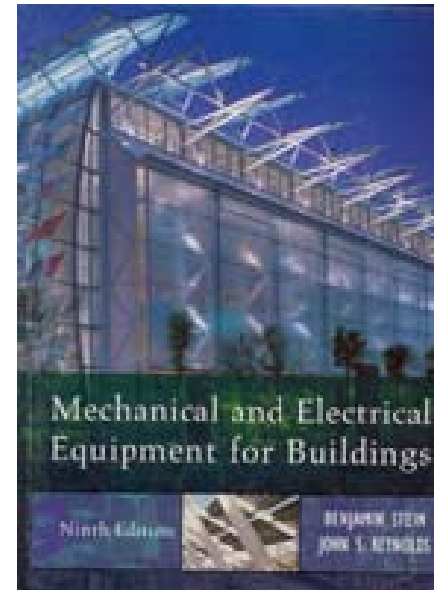
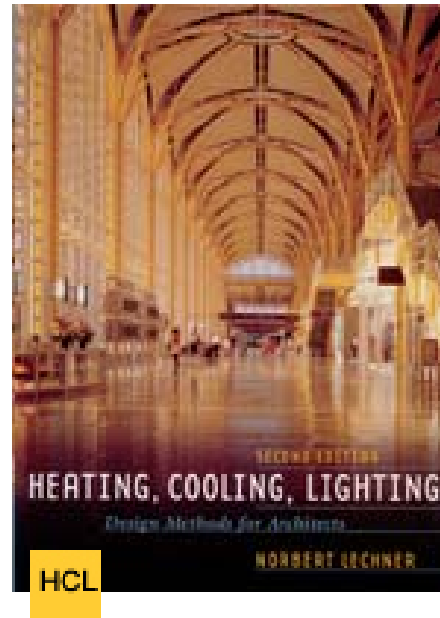
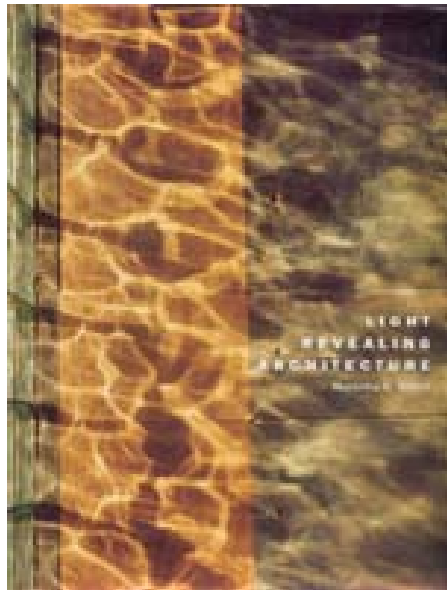
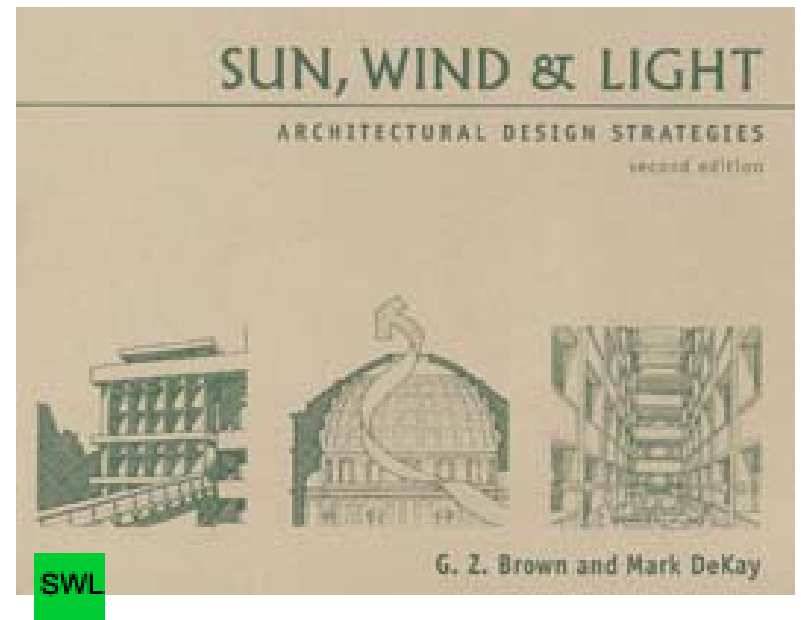

Daylighting does not equal sunlight!

Daylighting is about bringing natural LIGHT into a space.

Many daylit spaces do not WANT or NEED direct sunlight.



Daylighting concepts prefer *diffuse or indirect* lighting.

With the proper use of shading devices to block direct sun penetration into the space, all exposures of the building can receive diffuse light rather than direct sunlight.

It is necessary to differentiate strategies as a function of building use.

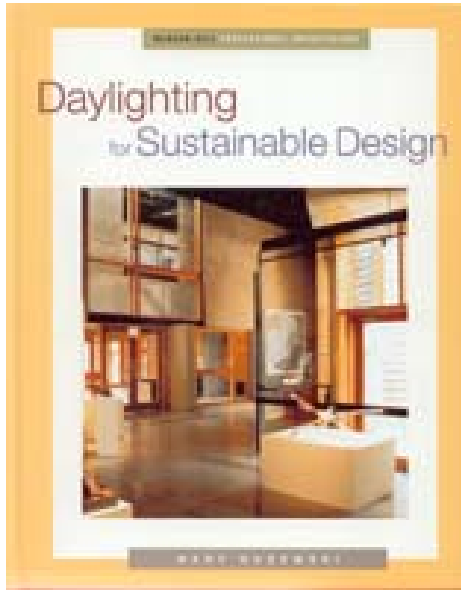

DIRECT SUNLIGHT is about **FREE HEAT**. 

DAYLIGHT (diffuse light) is about free **LIGHT**. 

Daylighting is **environmentally advantageous** because it:

- reduces the need for electric lighting
- therefore **reducing the energy** needed to power the lights
- **reducing the heat** generated from the lights
- thereby **reducing the cooling** required for the space

Other proven social/health benefits of daylighting:

- improves productivity and worker well being
- this has been translated into a reduction in sick days, which has saved some companies hundreds of thousands of dollars
- increased education in children: daylit schools have been proven to assist in higher levels of achievement and a decrease in dental problems!
- Daylighting is also worth 2 basic LEED points in the Interior Environmental Quality category

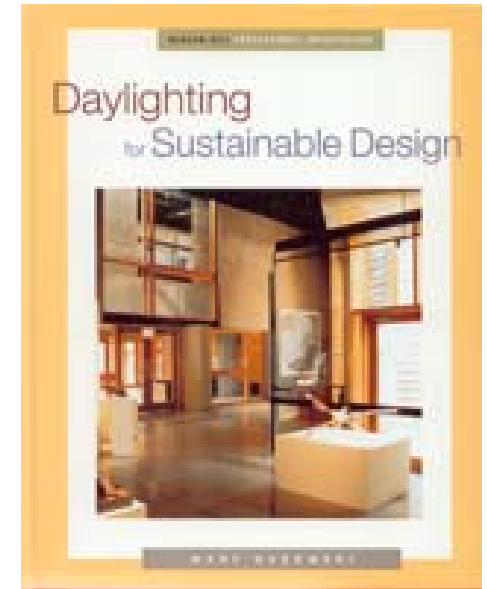

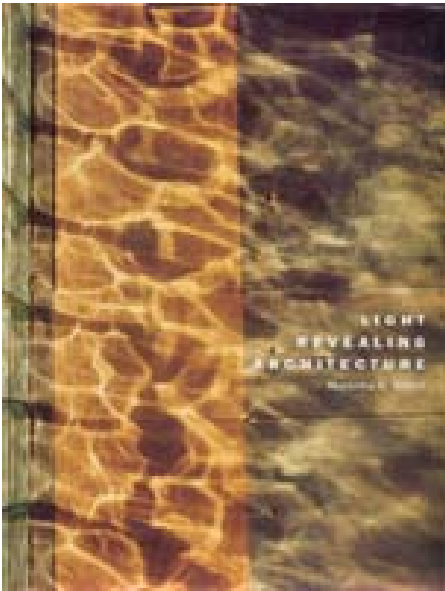

Light Revealing Architecture: Marietta Millett

Light Revealing **Experience**

Light Revealing **Form**

Light Revealing **Space**

Light Revealing **Meaning**

Light is an important architectural DESIGN TOOL. It has the ability to bring architecture to life. It relates to the use and cultural identity of the building.

Light revealing EXPERIENCE

Seattle Public Library |
Rem Koolhaas

Light revealing FORM



EMP, Seattle | Frank
Gehry Architect

Light revealing SPACE



British Museum Courtyard |
Foster + Partners

Light revealing MEANING



The Pantheon, Rome

Glossary of Terms

Measurable Photometric Quantities

When attempting to measure or quantify light, obviously the fewer the number of different units the better.

For example, there is only one SI unit for distance (the metre) and one for mass (the kilogram).

Light, however, is a little more complex as it actually goes through a **number of stages** during the course of any measurement

production (making), transmission (sending), incidence (hitting) and reflection (bouncing)

Each stage is a different quantity with a different set of units by which it is measured.

Glossary of Terms

Measurable Photometric Quantities

LUMINANCE (production/reflection): The luminous **intensity** (photometric **brightness**) of a **light source or reflecting surface** including factors of reflection, transmission and emission. Units are **candelas** per sq.ft. or per sq.m.



LUMINOUS FLUX (transmission): The **flow of light** from a source to a receiving surface, measured in **lumens**. ▶

ILLUMINANCE (incidence): The measure of light **intensity striking** a surface. The concentration of incident luminous flux, measure in **foot-candles** or **lux**.



Glossary of Terms

Measurable Photometric Quantities

LUMEN: The basic unit in photometry, **measuring the rate of light flow** (luminous flux).

Each square foot (square metre) of spherical surface surrounding a one candela (candle power) light source receives one lumen of light flux. Lumen is the unit used in both Imperial and SI units. One lumen produces a **1 foot-candle** (lux) **illuminance**.

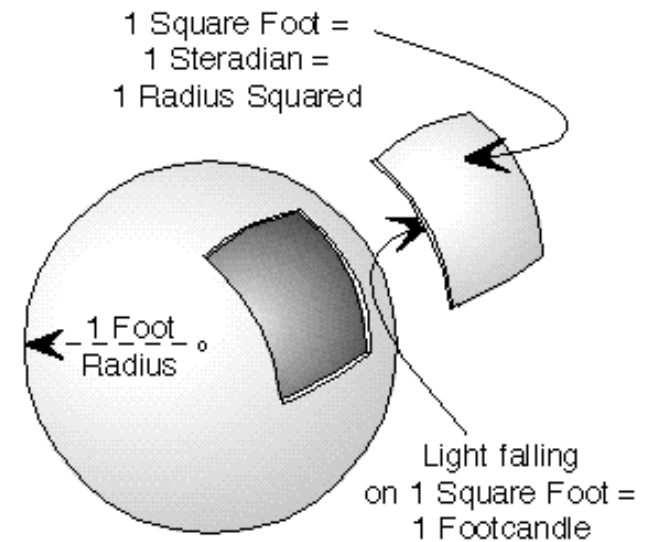

Glossary of Terms

Measurable Photometric Quantities

CANDELA: an SI unit of **luminous intensity**. An ordinary candle has a luminous intensity of one candlepower. 

FOOT-CANDLE: (fc) an imperial measure of **illuminance**.  |
The amount of direct light from one candle falling on a square foot of surface one foot away (lumens/ft²)

LUX: An SI measure of **illuminance**. The amount of light from one candle falling on a square metre of surface one metre away (lumens/m²).

$$1 \text{ lux} * 0.0929 = 1 \text{ foot-candle}$$

$$1 \text{ foot-candle} * 10.764 = 1 \text{ lux}$$

IP = Imperial

AS = American Standard

SI = System International

$$1 \text{ lux} * 0.0929 = 1 \text{ foot-candle}$$

$$1 \text{ foot-candle} * 10.764 = 1 \text{ lux}$$

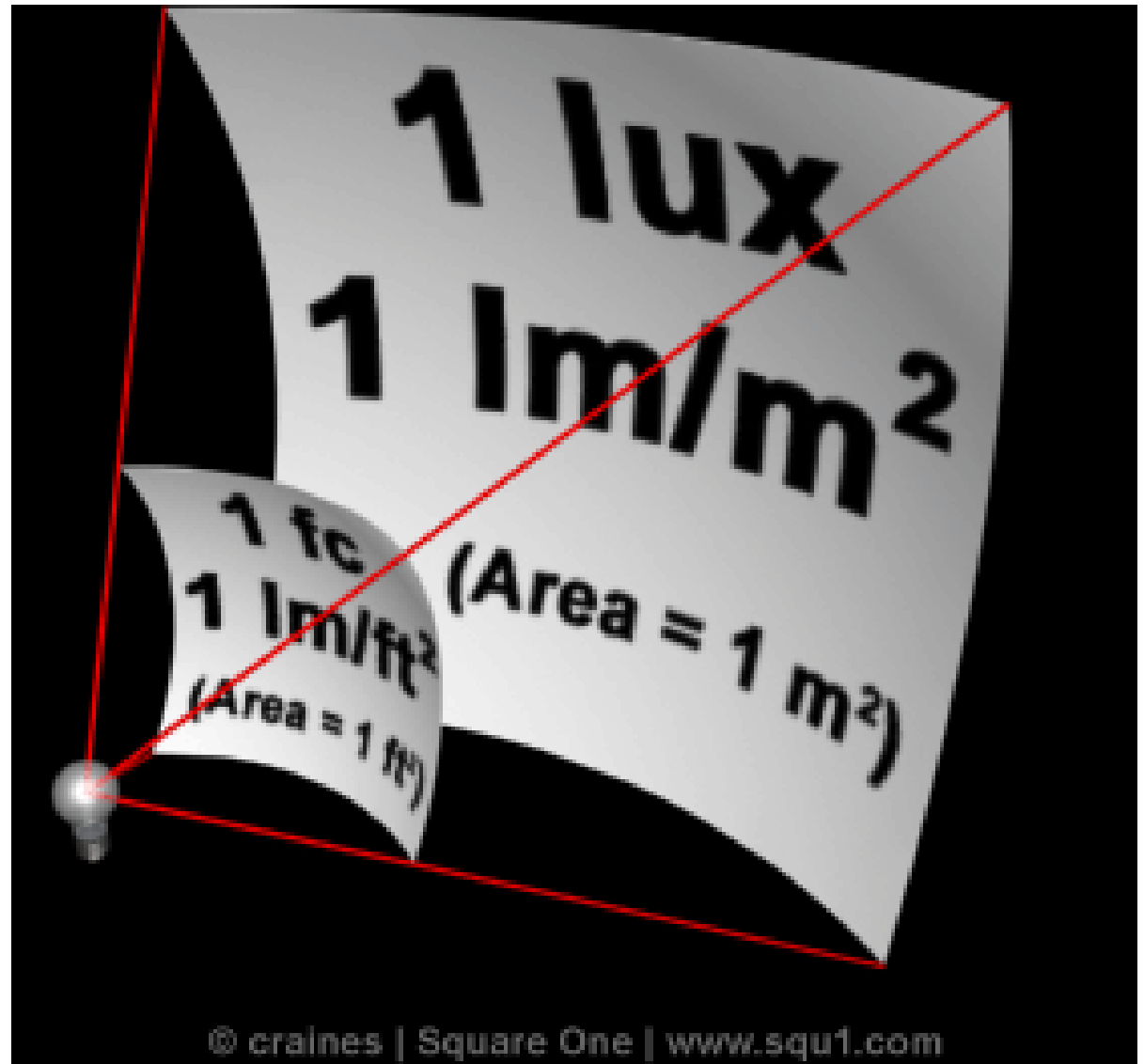

Design Requirements

CIE (Commission International de l'Eclairage) and IES (Illuminating Engineers Society) have published recommended lighting levels for various tasks.

50 lux (4.65 footcandle)

- Car Parks
- Main Entrances and exits
- Store rooms
- Outdoor platforms
- Stables
- Hotel bedrooms
- Garages



100 lux (9.29 footcandle)

- Corridors and passageways
- Stairs and escalators
- Entrance gates
- Changing rooms
- Rest rooms
- Raw material stores
- Machine rooms
- Loading bays
- Foyers
- Domestic living rooms

200 Lux (18.58 footcandle)

- Lifts and lift lobbies
- Waiting rooms
- Medical stores
- Machine assembly rooms
- Finished goods stores
- Vaults and strong-rooms
- Print rooms
- Shopping centre circulation areas
- Airport lounges
- Museum areas (general)
- School assembly halls
- Lecture theatres
- Gymnasiums
- Sports spectator areas

400 Lux (37.16 footcandle)

- Enquiry desks and counters
- Food preparation areas
- Consulting and treatment rooms
- General clerical offices
- Library reading tables
- Assembly hall platforms
- Classroom white-boards
- Laboratories
- Hospital dispensing rooms
- Workshop benches



600 Lux (55.74 footcandle)

- Engine testing rooms
- Cutting and assembly rooms
- Inspection and product testing benches
- Computer rooms
- Drawing board task lighting
- Food sales counters
- Cashier counters
- Supermarkets
- School art rooms
- Vision testing rooms
- Sewing rooms



900 Lux (83.61 footcandle)

- Electronics assembly areas
- Instrumentation workbenches
- Supermarket displays

1200+ Lux (111.48 footcandle)

- Sorting and grading areas
- Clothing inspection areas
- Hand engraving workbenches
- Jewellery workbenches
- Boxing rings



The more visual acuity required, the more light provided!

TABLE 12.9 GUIDELINES FOR ILLUMINATION LEVELS

Approximate Type of Activity	Footcandles*
1. General lighting throughout space	
a. Public spaces with dark surroundings	3
b. Simple orientation for short, temporary visits	8
c. Working spaces where visual tasks are only occasionally performed	15
2. Illumination on task	
a. Performance of visual tasks of high contrast or large size	30
b. Performance of visual tasks of medium contrast or small size	75
c. Performance of visual tasks of low contrast and very small size over a prolonged period	150

*Because of the variability of actual conditions, the final design illumination values will often be 50 percent larger or smaller than these guideline values. Precise values are not appropriate because of the large tolerance of human vision, and because the quality of the light determines whether more or less light is required. These values can be reduced by 25 percent if the quality of the lighting is very high and they should be increased 35 percent if the average age is over forty. This table is adapted from IESNA tables for recommended illumination levels.

Adequate lighting levels are not globally the same!

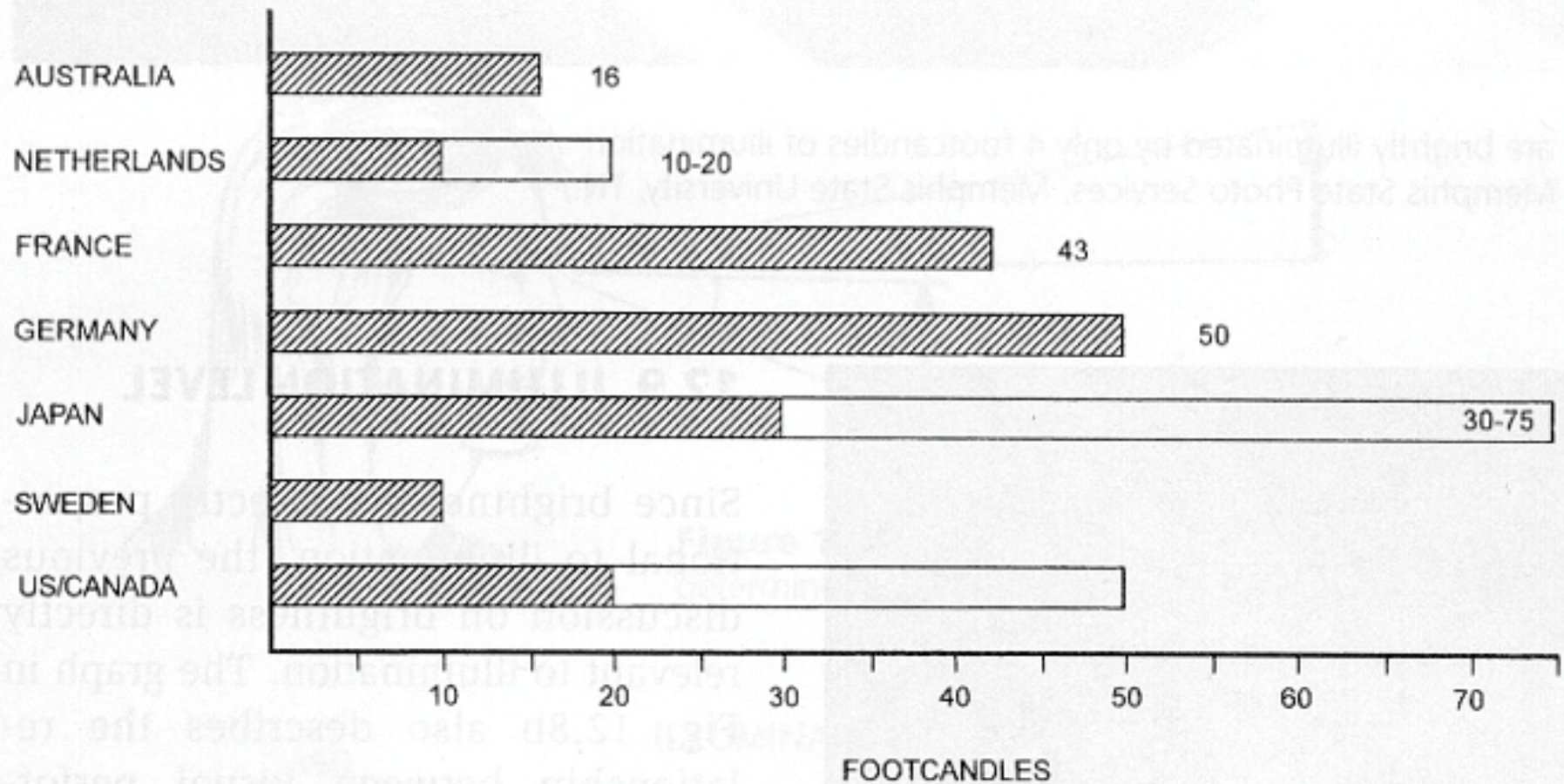
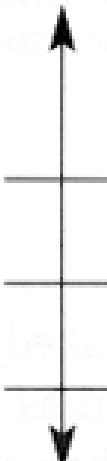



Figure 12.9 A comparison of recommended lighting levels for general office work in horizontal footcandles. Note that some countries recommend ranges instead of a specific value. (After Mills and Borg. "Rethinking Light Levels." IAEEL Newsletter, 7 (20), 4-7 (1998).)

TABLE 12.5 COMMONLY EXPERIENCED BRIGHTNESS LEVELS

	Brightness (cd/sq. ft.)*	
Sidewalk on a dark night	0.0003	
Sidewalk in moonlight	0.003	
Sidewalk under a dim streetlight	0.03	
Book illuminated by a candle	0.3	
Wall in an office	3	
Well-illuminated drafting table	30	Normal indoor brightness
Sidewalk on a cloudy day	300	Normal outdoor brightness
Fresh snow on a sunny day	3,000	
500-watt incandescent lamp	30,000	



HCL

*For S.I., (cd/sq. m.) \approx (cd/sq. ft.) \times 11

LUMINANCE (production/reflection): The luminous **intensity** (photometric **brightness**) of a **light source or reflecting surface** including factors of reflection, transmission and emission. Units are **candelas** per sq.ft. or per sq.m.

Design Sky Values

Design Sky values are derived from a statistical analysis of outdoor illuminance levels. →

They represent a horizontal illuminance level that is exceeded 85% of the time between the hours of 9am and 5pm throughout the working year. Thus they also represent a **worst-case scenario** that you can design to and be sure your building will meet the desired light levels at least 85% of the time.



Sky Types

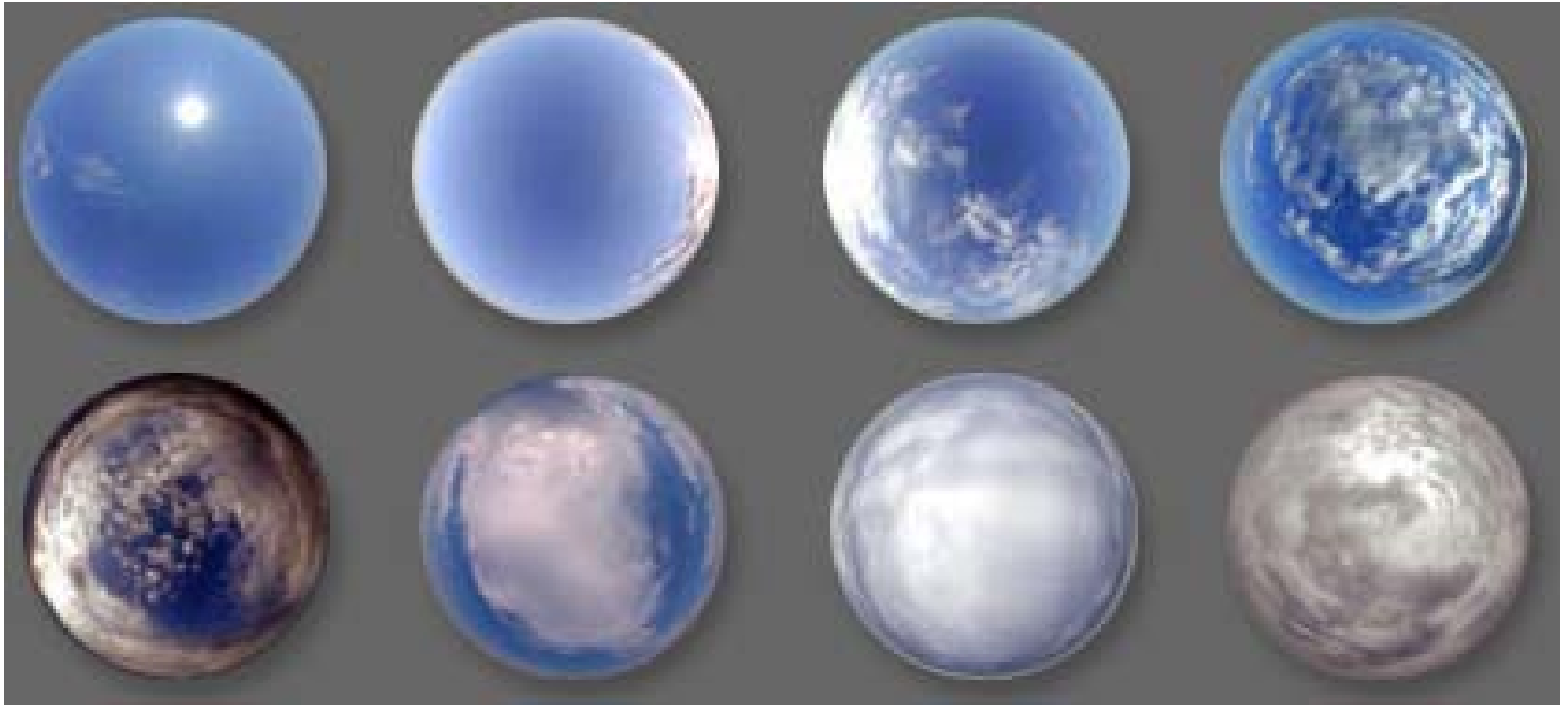

Examples of different sky distributions: These images are the result of taking photographs using a fish-eye lens. Such images capture the full hemisphere of the sky, with the horizon around the perimeter and the zenith in the centre.

The different basic sky types, **clear**, **uniform** and **overcast**, as defined by the CIE (Commission International de l'Eclairage) give varying amounts of light for use in daylighting the building. Local climate must be considered when designing for daylight.

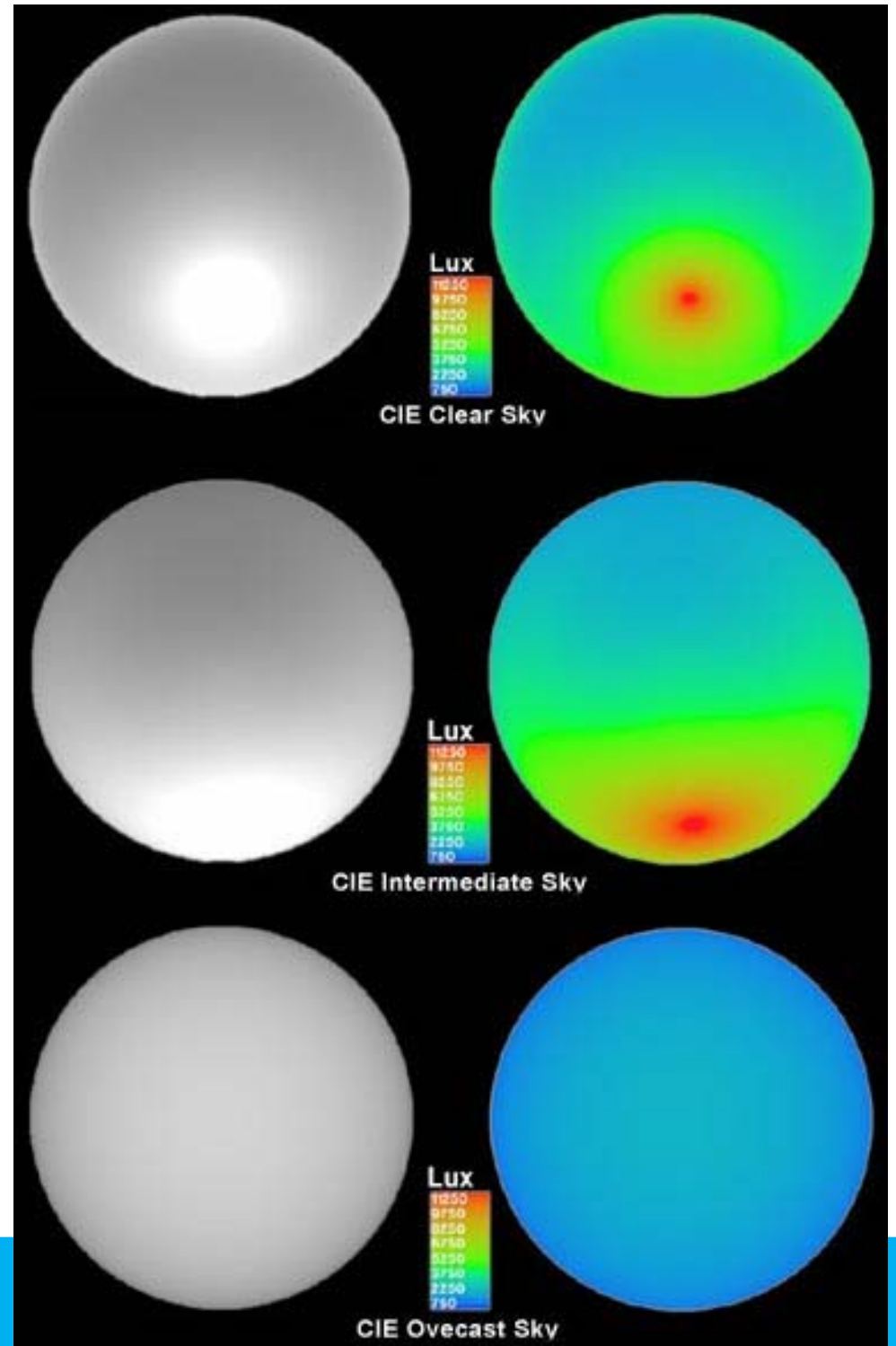

The "sky dome" for the location must also be considered when designing for daylighting. Local obstructions to the sky dome will affect the amount and quality of light received.

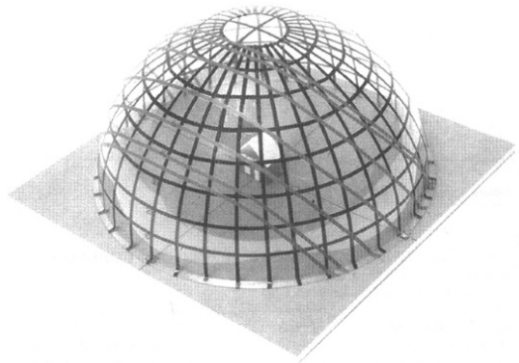

Figure 6.11b A model of the sky dome. The sun paths for the 21st day of each month are shown. Only seven paths are needed for twelve months because of symmetry (i.e., May 21 is the same path as July 21).



Building spacing and orientation will also need to be factored in when determining the amount of available light or sunlight for the building on its various sides.



North-south canyon in housing development at Yonge and 401, Toronto

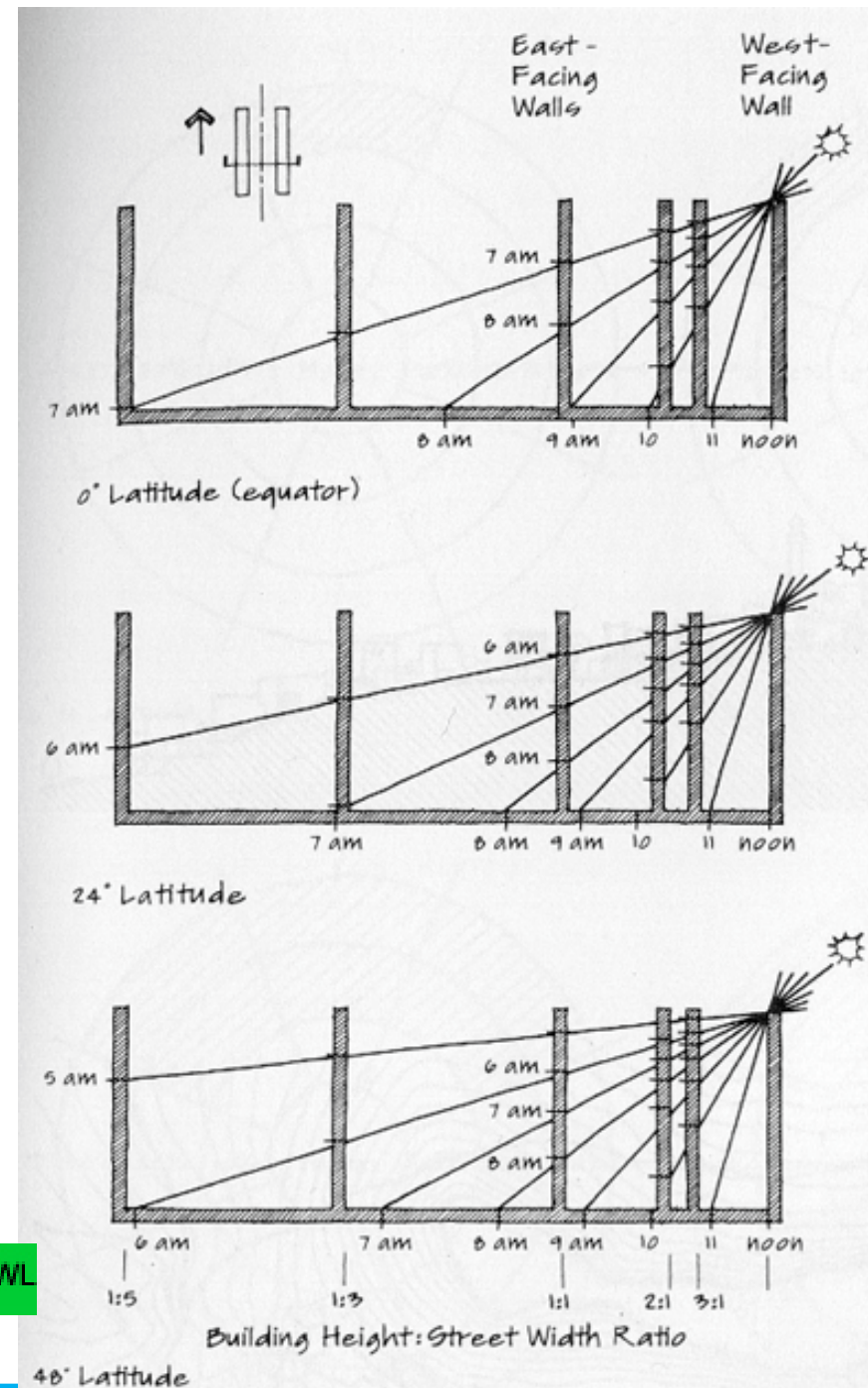

SWL

Impact of Cross-Section on Shading Patterns, North-South Canyons on Jun 21

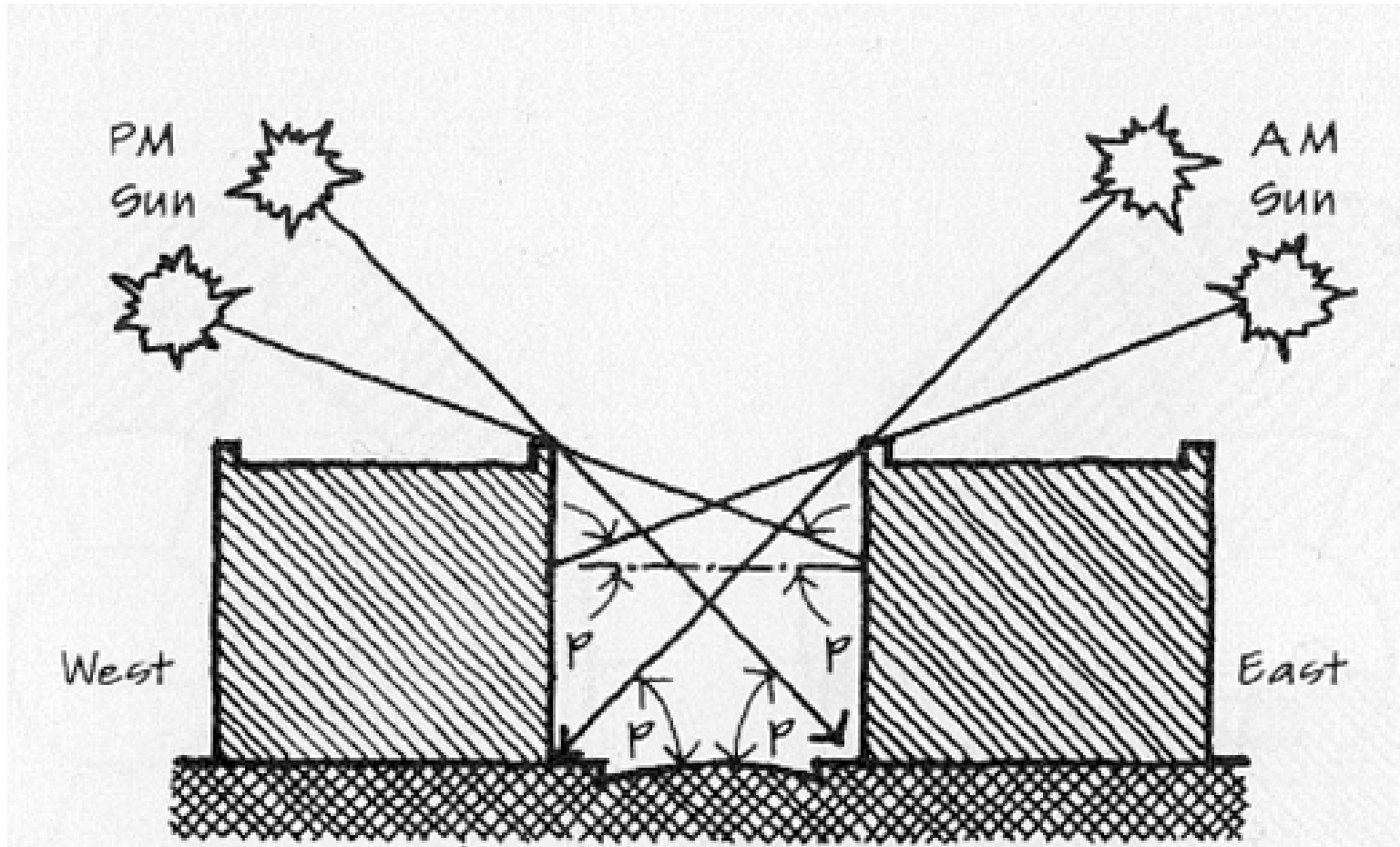

Profile Angle for North-South Canyons

SWL



North-south canyon on Avenue Road, north of St. Clair

Looking due east between two tall apartment buildings. Daylight is limited in this direction as well.

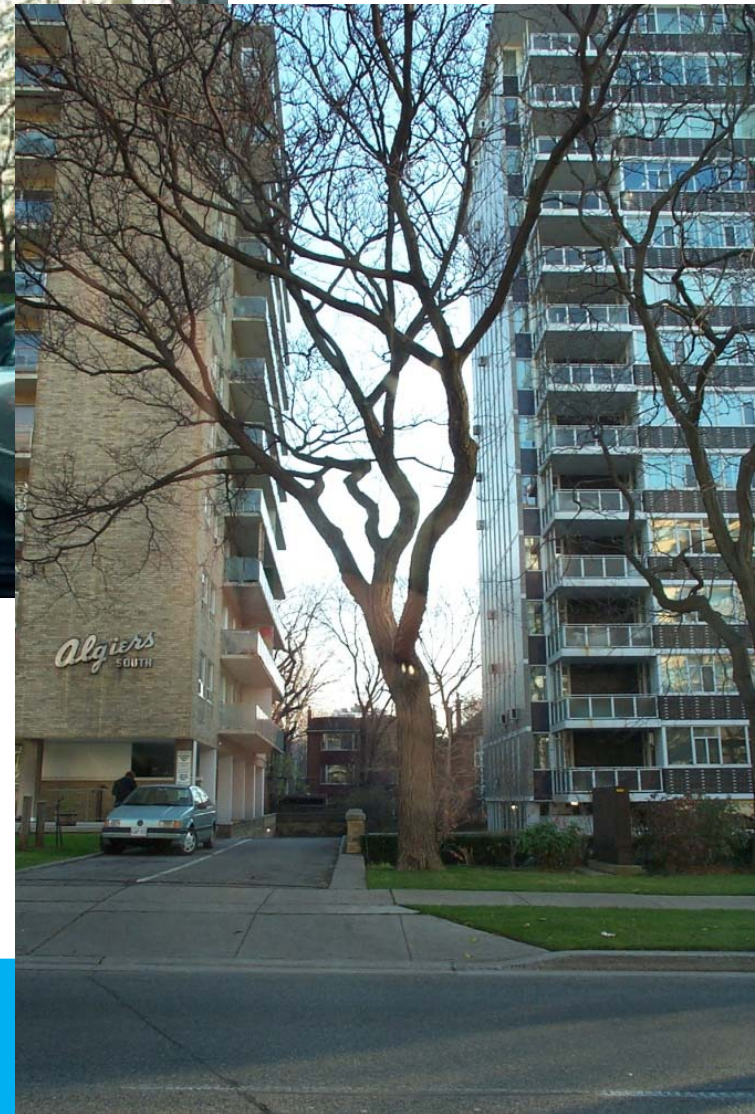

Daylight Factor

The daylight factor (DF) is a very common and easy to understand measure for expressing the daylight availability in a room under the same sky conditions.

It describes the **ratio of outside illuminance over inside illuminance**, expressed in per cent. The **higher the DF the more natural light** is available in the room.

Range is usually 0 - 100%, but for most rooms is usually 1 - 10%.

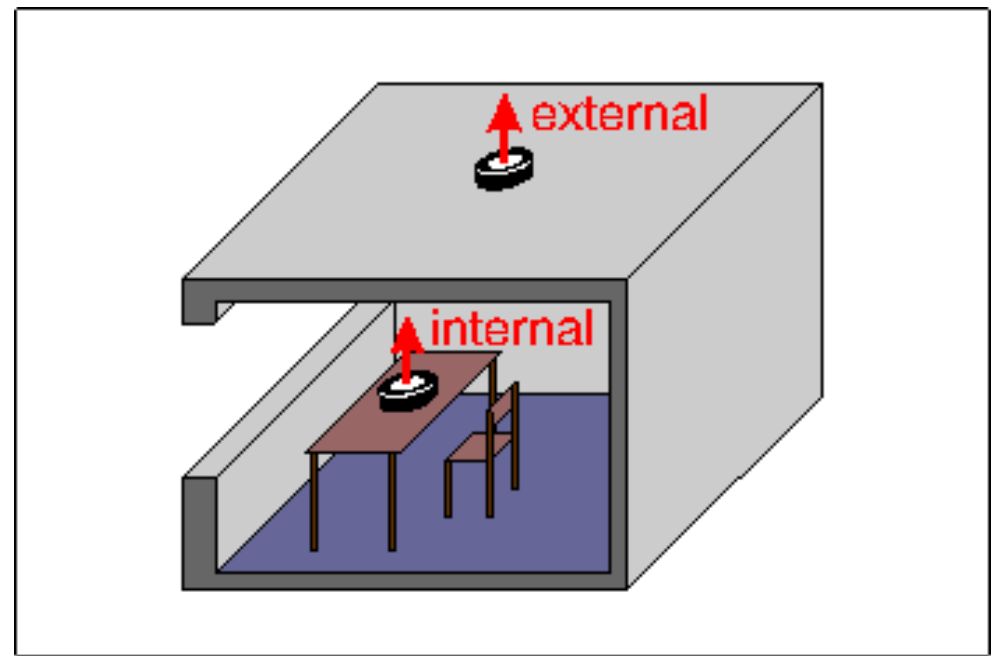

The definition of a daylight factor

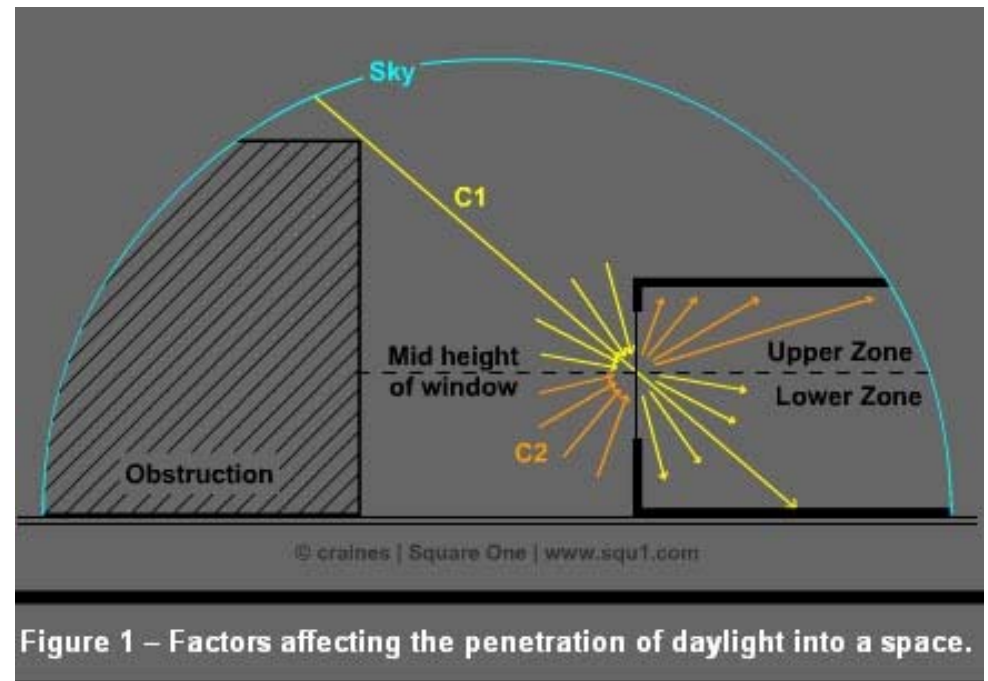

Figure 1 – Factors affecting the penetration of daylight into a space.

Daylight Factor



2% average daylight factor



5% average daylight factor

Daylight Factor

Building Type	Recommended Daylight Factor %
Dwellings	
Kitchen	2
Living room	1
Bedroom	0.5
Schools	2
Hospitals	1
Offices	
General	1 to 2
Drawing offices	2
(on drawing boards)	6
Typing and computing	4
Laboratories	3 to 6
Factories	5
Art galleries	6
Churches	1 to 2
Public buildings	1

Note: **LEED** daylighting credits are tied to DF!

6-1 Daylight-factor curve over the depth of a room with a single-skin facade.

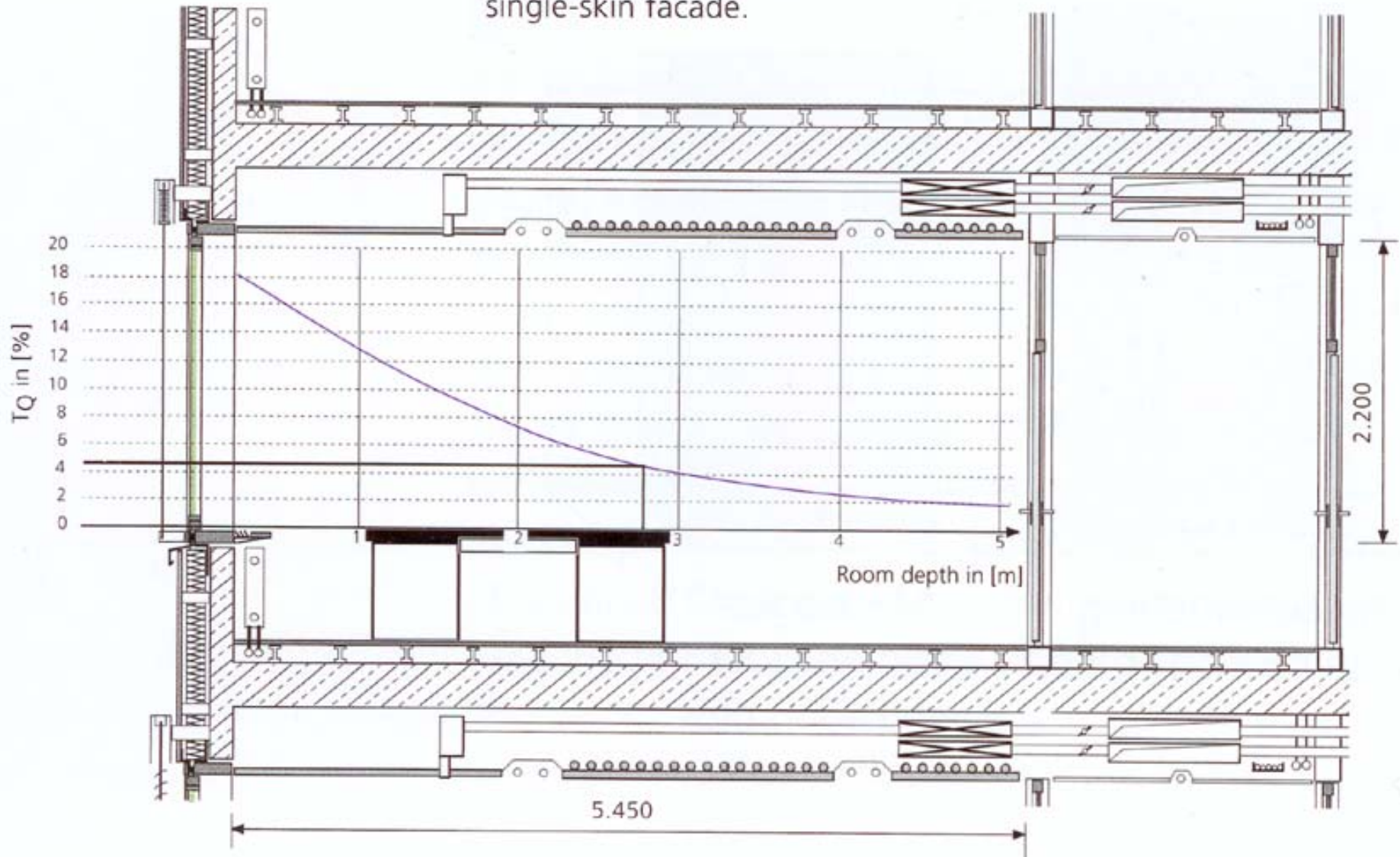

LEED requires a minimum Daylight Factor of 2% to qualify for any credits

ACTION STEPS

POINTS: 1+ **EP**
Daylight at least 75% of regularly occupied spaces (95% for E.P.)

EQc8.1: Daylight and Views—Daylight

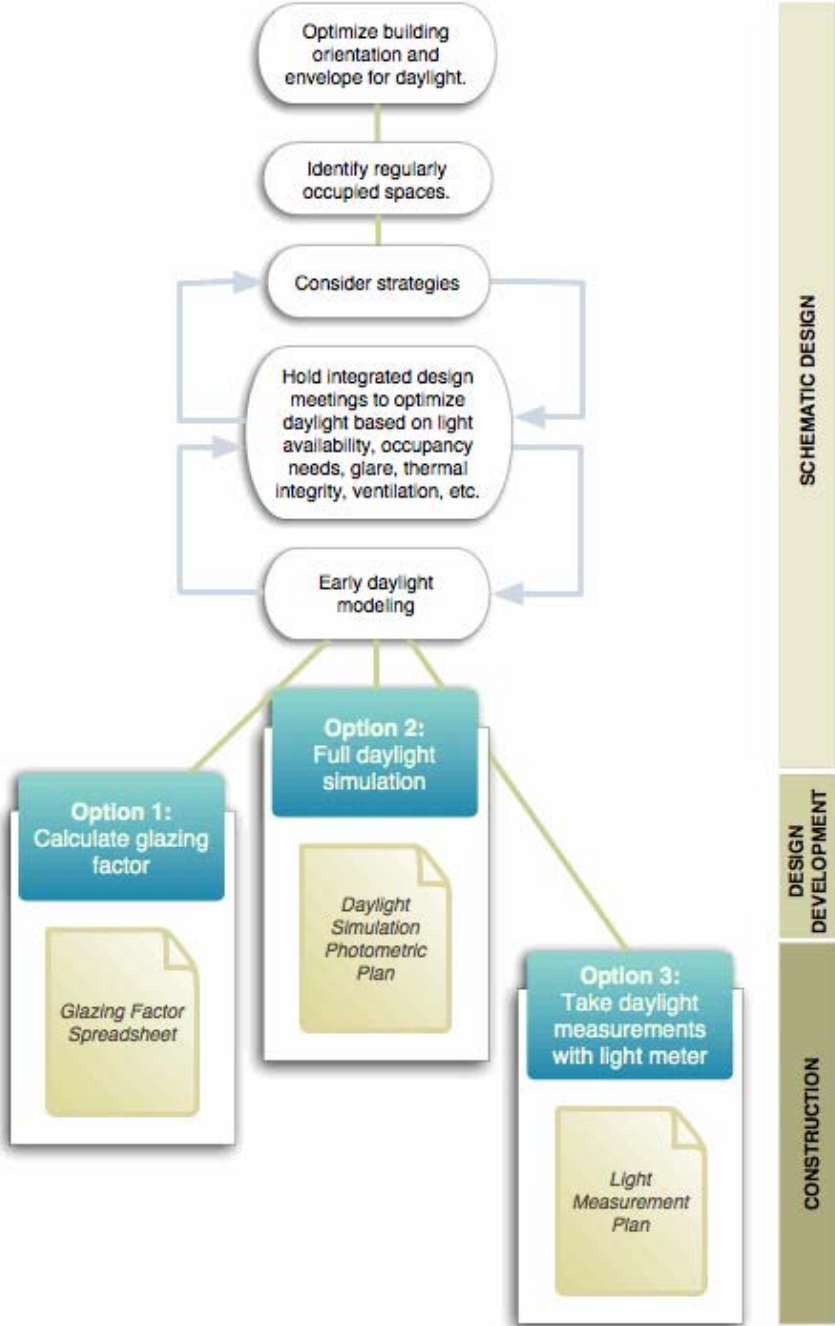

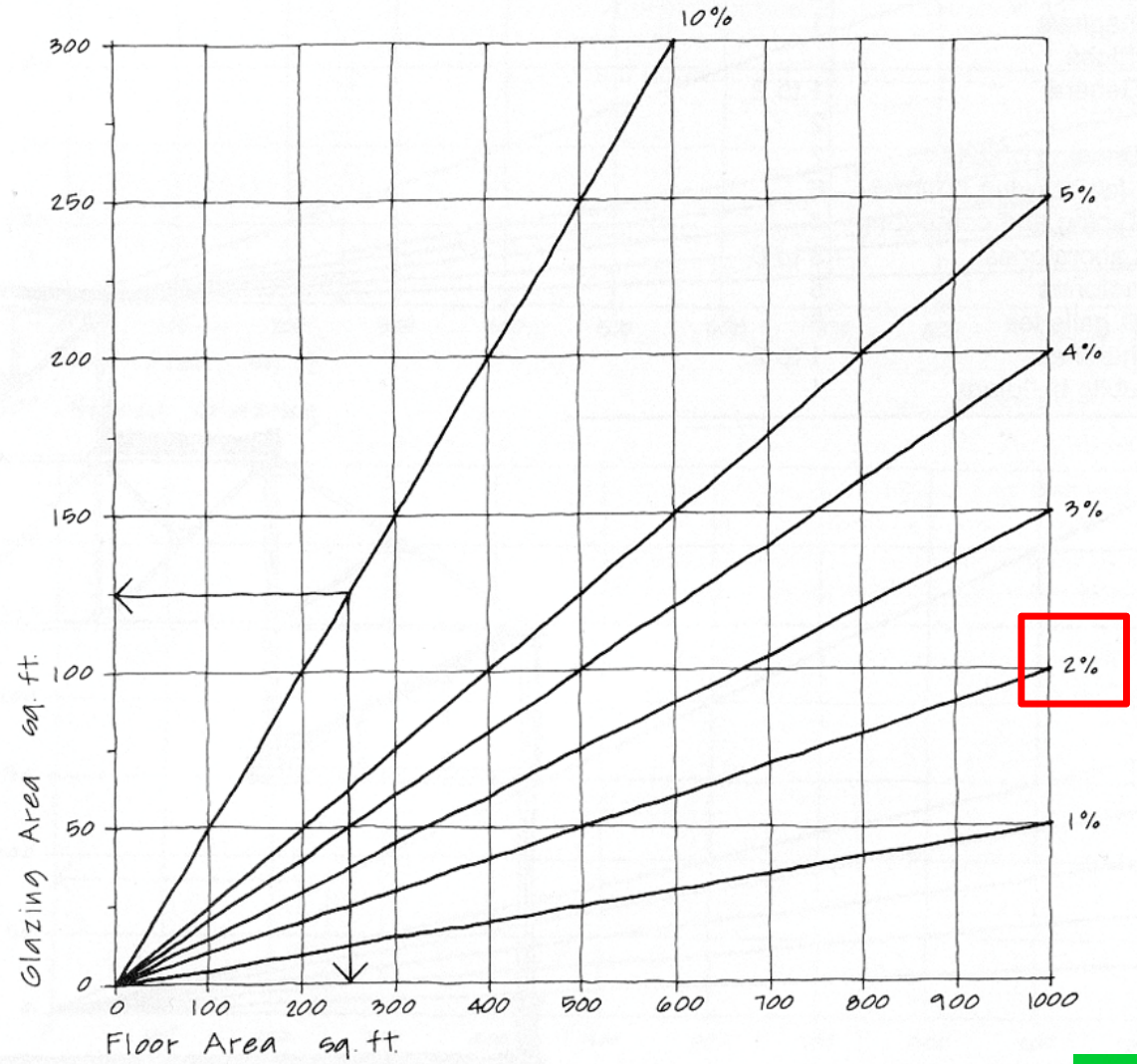
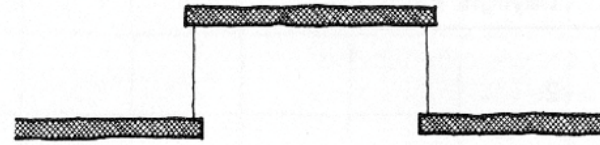

Daylight Factors for Sidelighting and Vertical Monitors

SWL

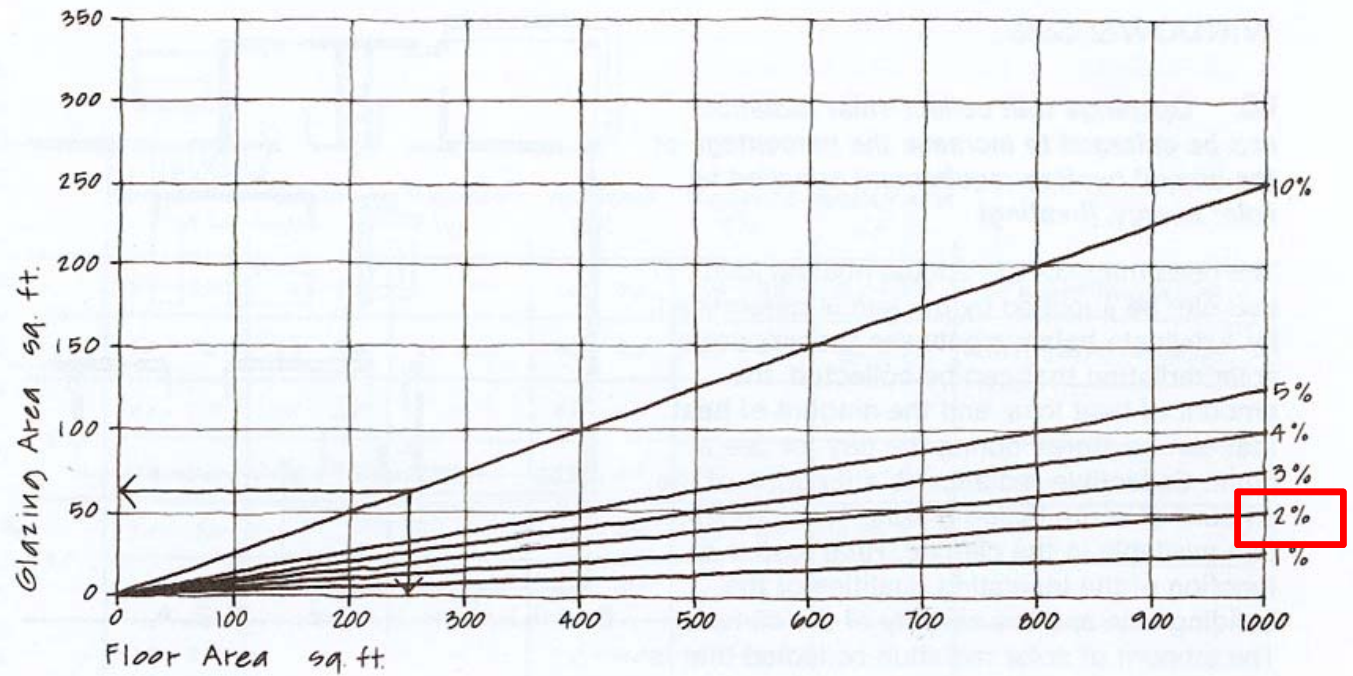
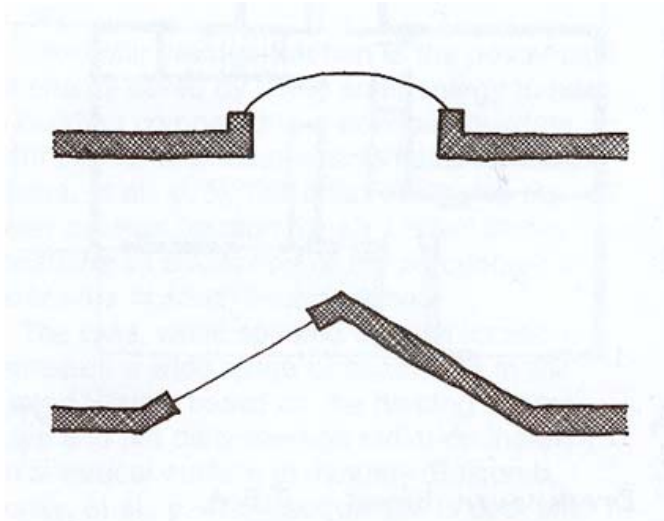

Daylight Factors for Horizontal and 30° Sloped Glazing

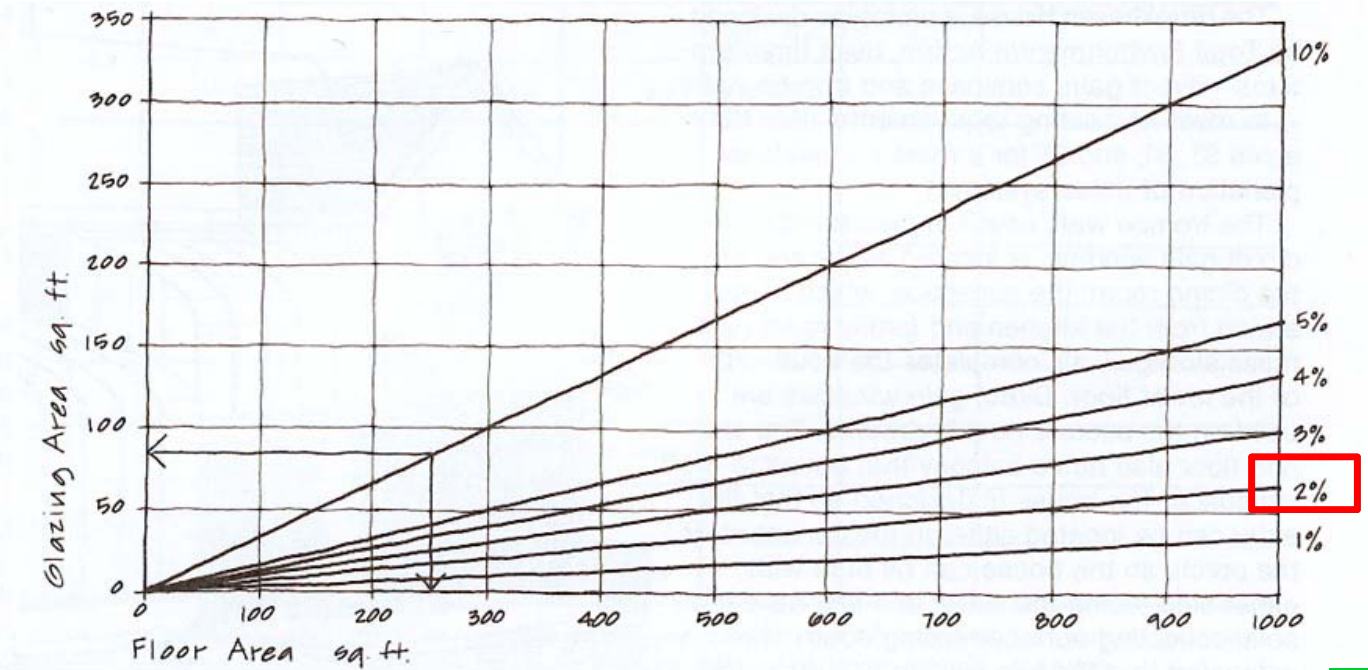
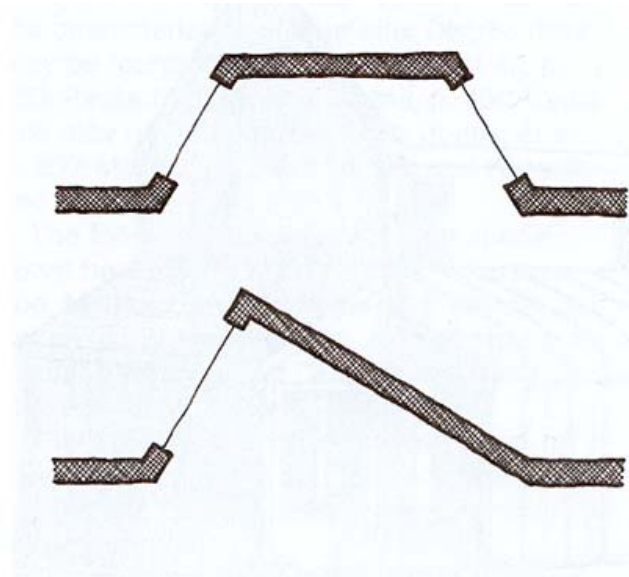

Daylight Factors for 60° Sloped Roof and Monitor Glazing



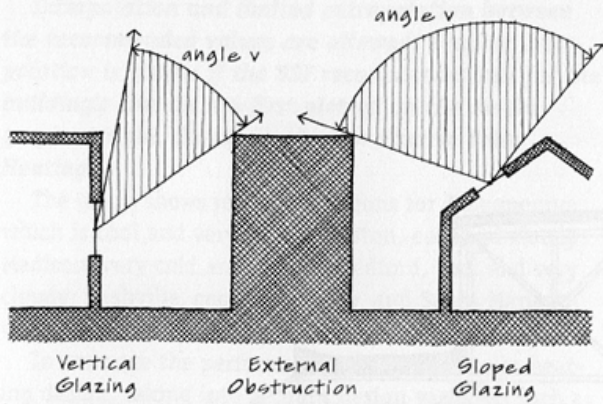

Sky View Angle (v) From Glazing

The graph assumes a 60% transmissivity for clear double glazing plus frame effects, a maintenance factor of 80%, an average room reflectance of 40%, and a fairly large room, about the size of a classroom. It was developed using a model from Littlefair (1988). If other glazing and frame types with poorer visible light transmission are used (Strategy 101), the glazing area will need to be increased proportionally. Because room size and proportions affect the pattern of internal reflections, light in small rooms is reflected more times before reaching the work plane than light in large rooms. **For small rooms, such as bedrooms and private offices, increase the glazing size from the graph by up to 60%. For very large rooms, such as a gymnasium, reduce the glazing size by up to 30%.**

For sidelighting, the daylight factors apply to a floor zone with a maximum depth into the room of 2.5 times the height of the window wall (Strategy 71). For top-lighting, the floor area associated with the glazing can be estimated by projecting 45° lines from the opening to the floor. If more than one opening type is used for the same area, the daylight factors may be added. An example of using more than one opening type is Albert Kahn's use of sidelighting and monitors in the **Packard Forge Shop** in Detroit, Michigan (Hildebrand, 1974, p. 57).

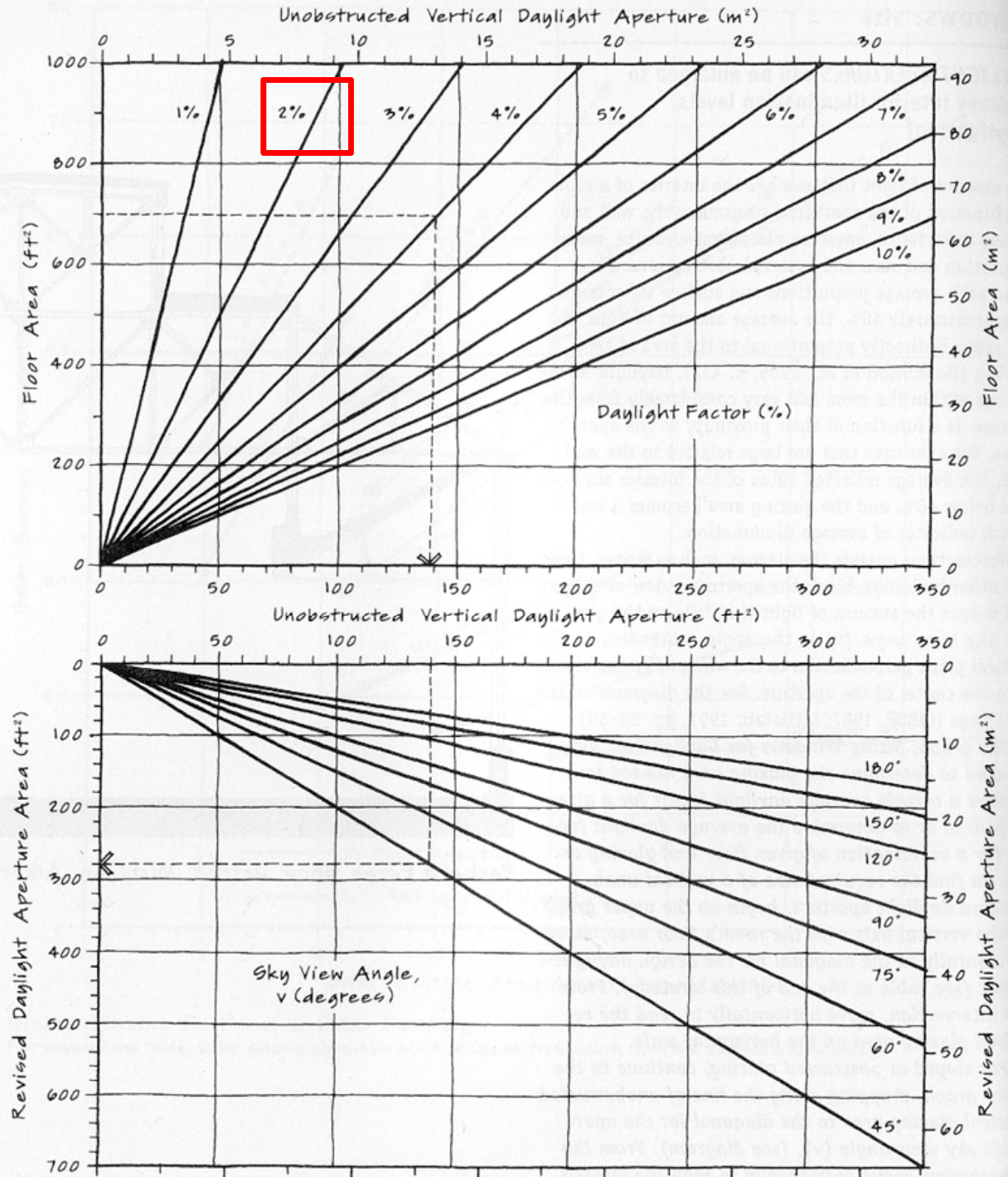

Sizing Windows for Daylighting

Reflectance of Materials + Colours

Surface	Recommended Reflectance (%)
Ceilings	70-80
Walls	40-80
Floors	20-40

Recommended Finish Reflectances



Color	Reflectance (%)
white	80-90
pale yellow & rose	80
pale beige & lilac	70
pale blue & green	70-75
mustard yellow	35
medium brown	25
medium blue & green	20-30
black	10

Daylight Reflectance of Colors

SWL

Reflector Finish	Reflectance (%)
Concrete	30-50
Old snow	40-70
New snow	80-90
Polished aluminum	75-95
Aluminized mylar	60-80
Polished stainless steel	60-80
White porcelain enamel	70-77
Acrylic with aluminized backing	85
Aluminum foil	86
Electroplated Silver, new	96



Not only the material, but also the texture of the finish affects reflectance.

Solar Reflectance of Finishes



Window Types + Light Distribution

Window

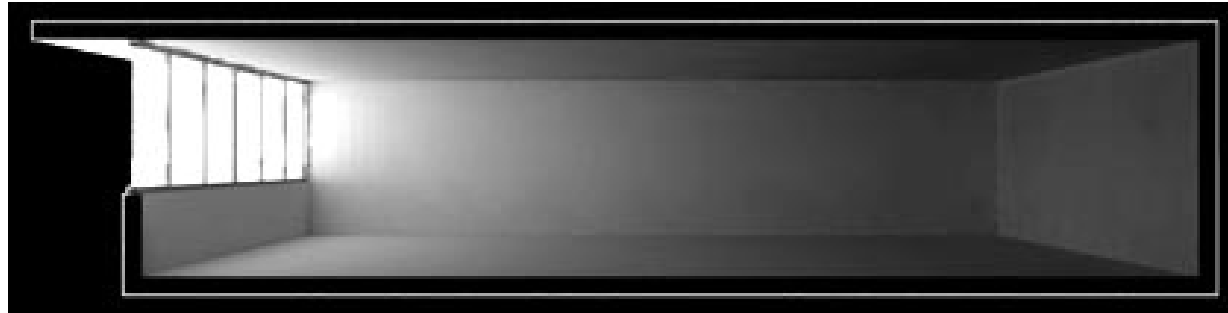

Windows
both sides

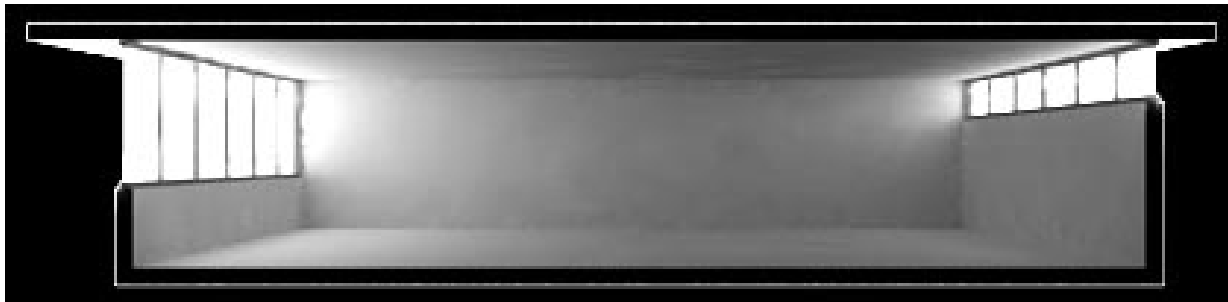

Lightshelf

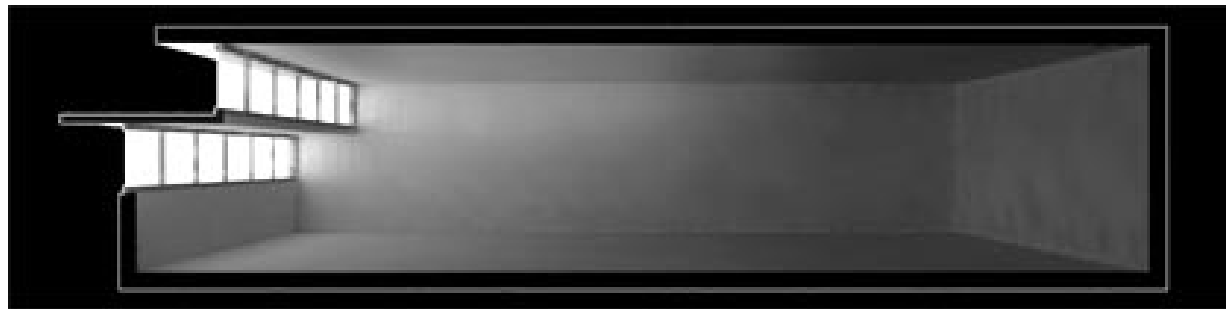

For distribution concerns think of bright vs. dark spots as well as room use. These images are for overcast bright sky conditions

Images from
squ1.com

Skylight

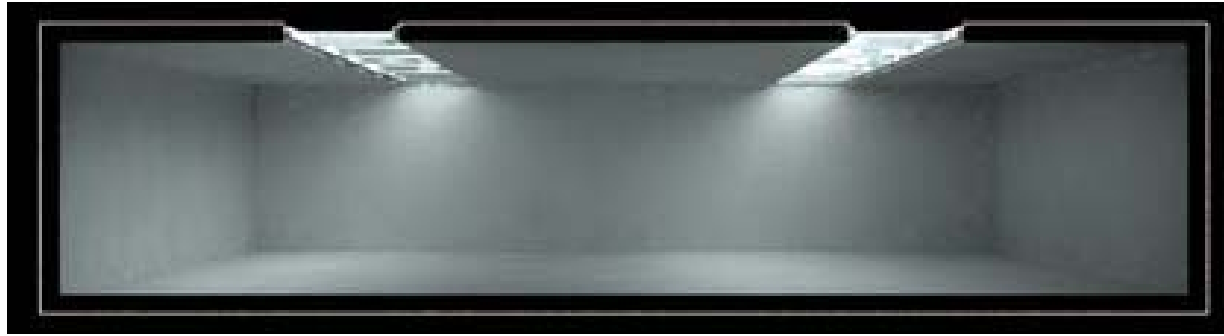

Roof monitor

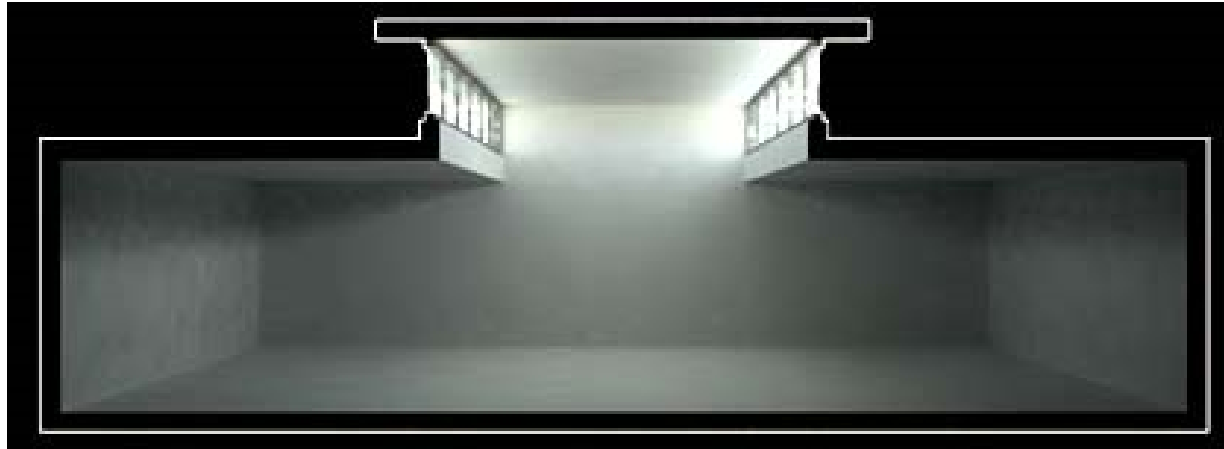

Sawtooth

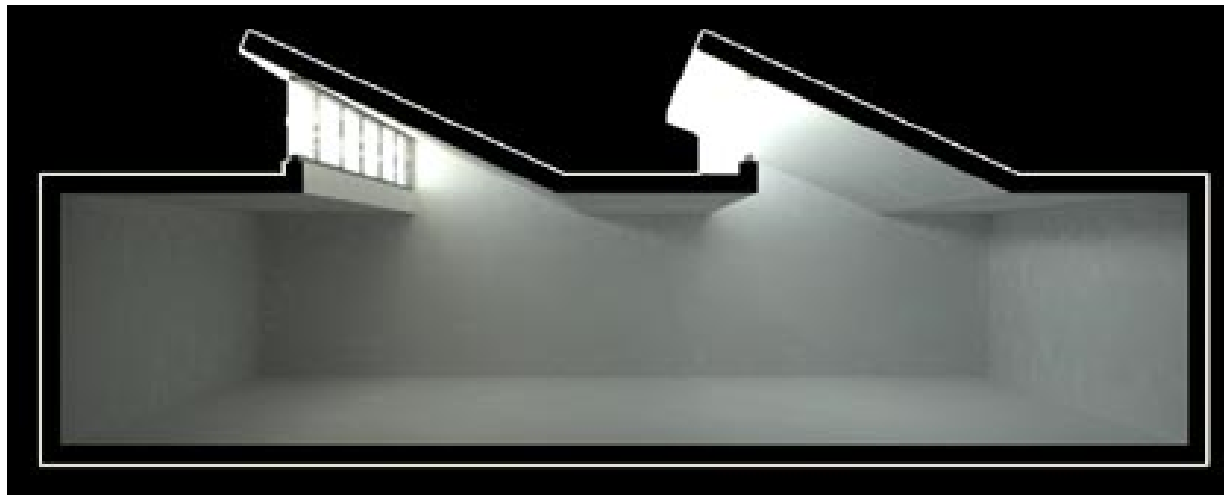

For distribution concerns think of bright vs. dark spots as well as room use. These images are for overcast bright sky conditions – so no sharp shadows...

Images from squ1.com

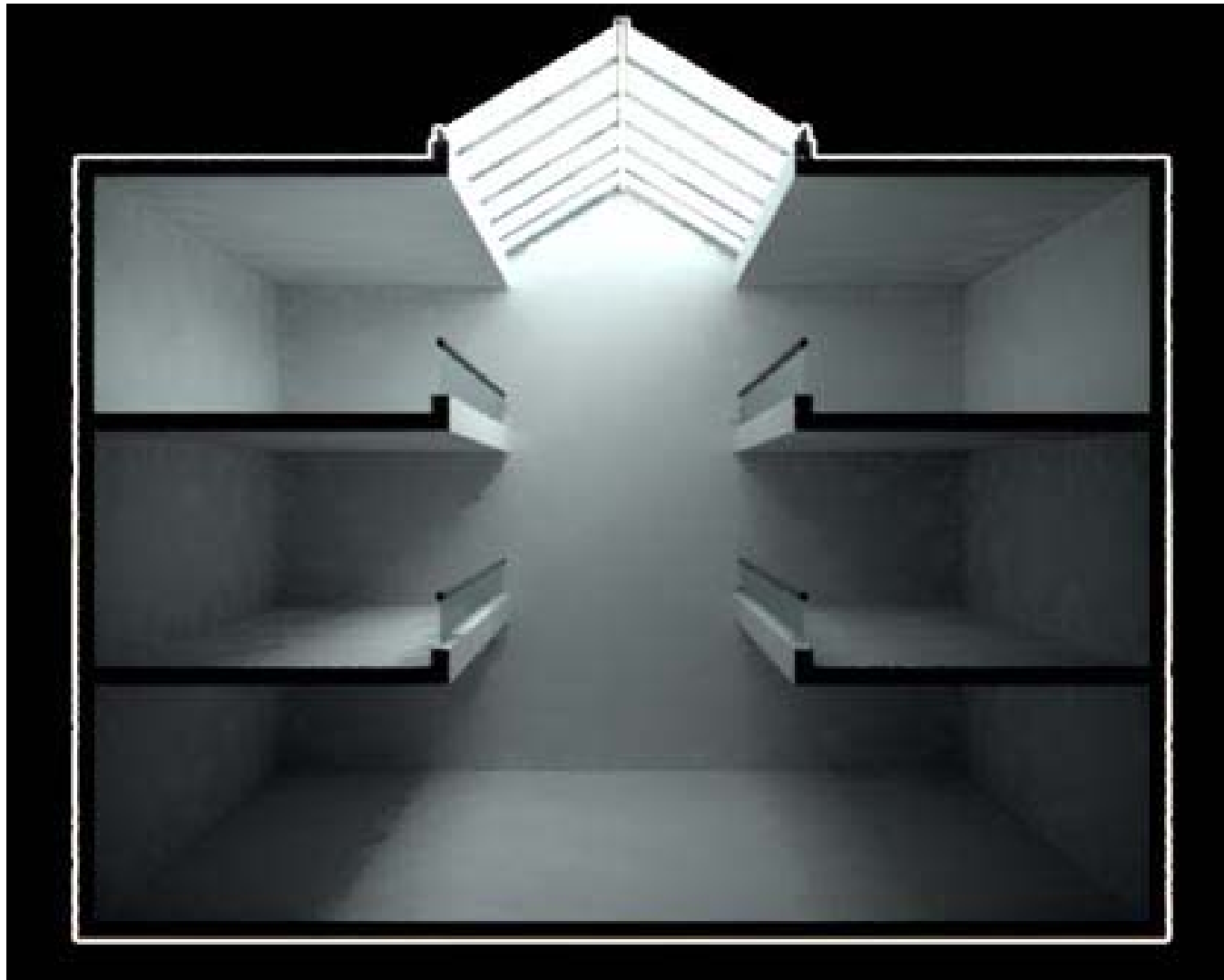

For distribution concerns think of bright vs. dark spots as well as room use. These images are for overcast bright sky conditions – so no sharp shadows...

Spaces nearer the top floor are appreciably brighter. More supplementary light is needed on the lower floors.

Images from squ1.com



Lightwell – provides more light directed to the lower floors

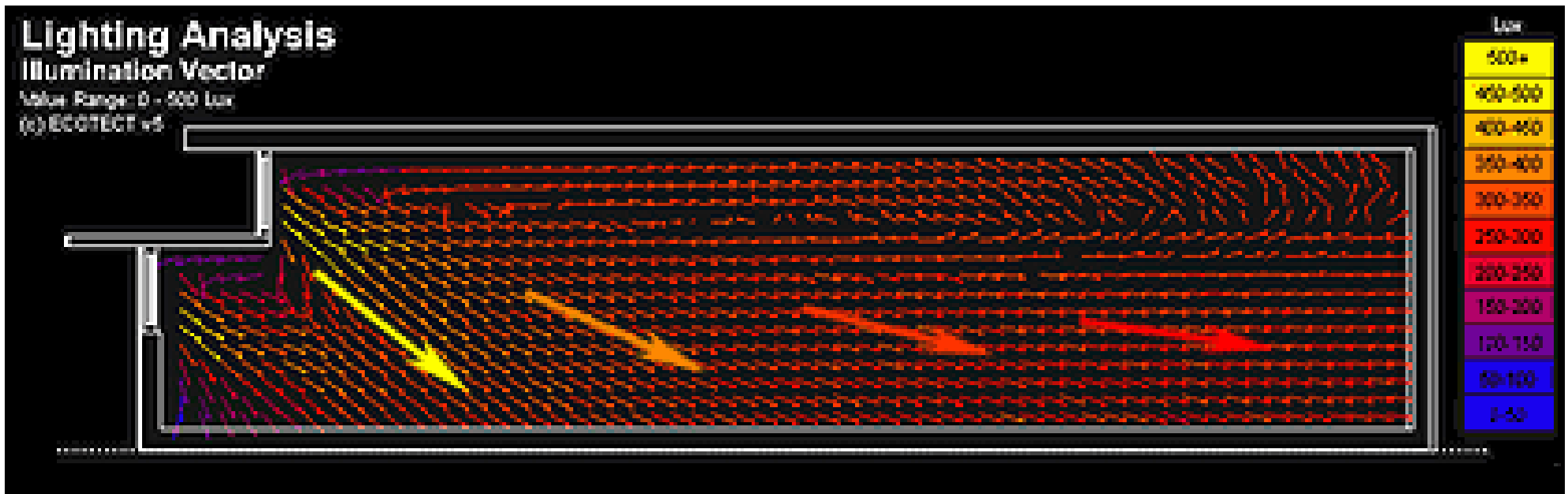
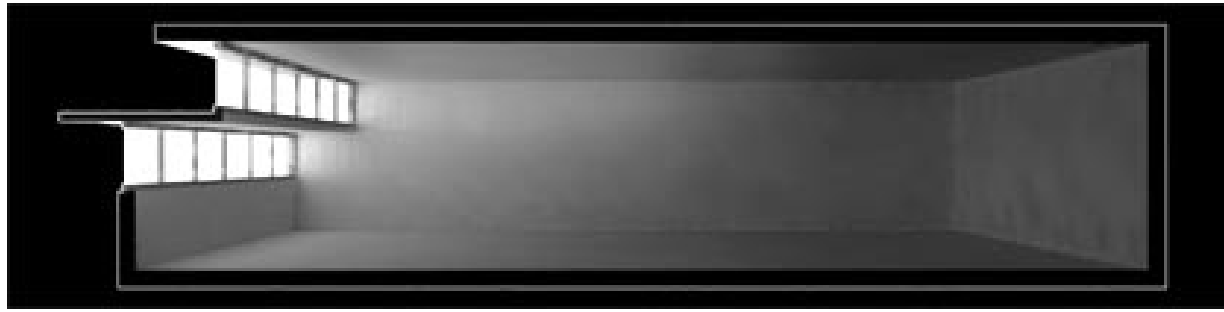

Cross section from ECOTECH showing how illumination vectors become more horizontal as sidelight travels deeper into a space.

Light intensity and distribution within the space must also be addressed as light is not uniform. This affects USE placement as well as supplementary and TASK lighting.

Designing Openings

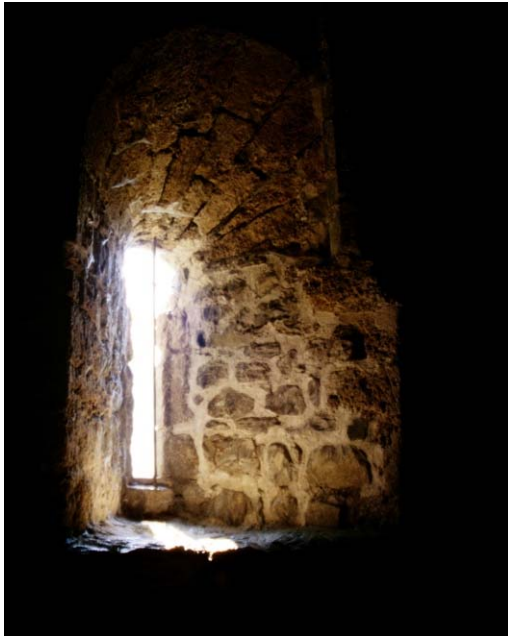

This splayed opening distributes light more widely than a deep cut would.

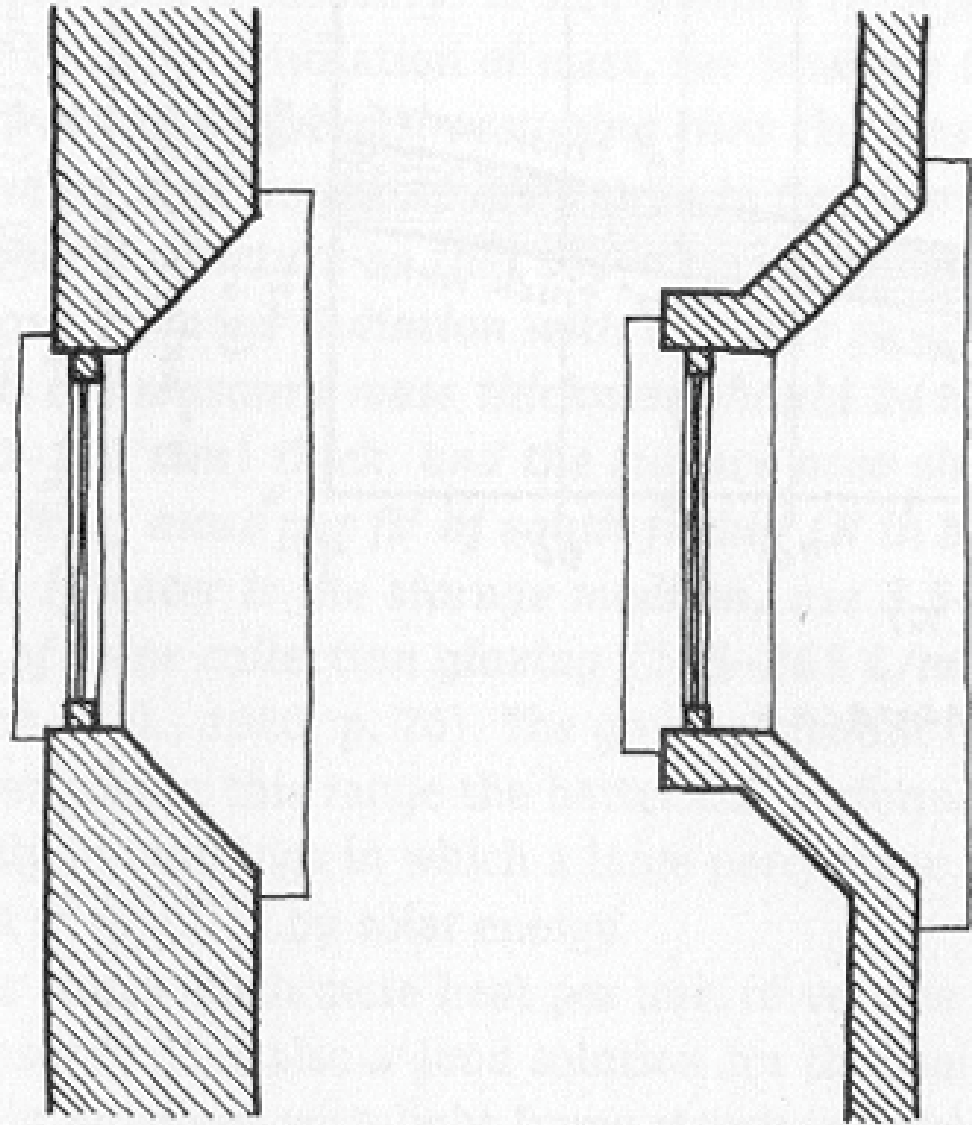

Thick Wall Splay

Thin Wall Splay

Splayed Window Jamb Options



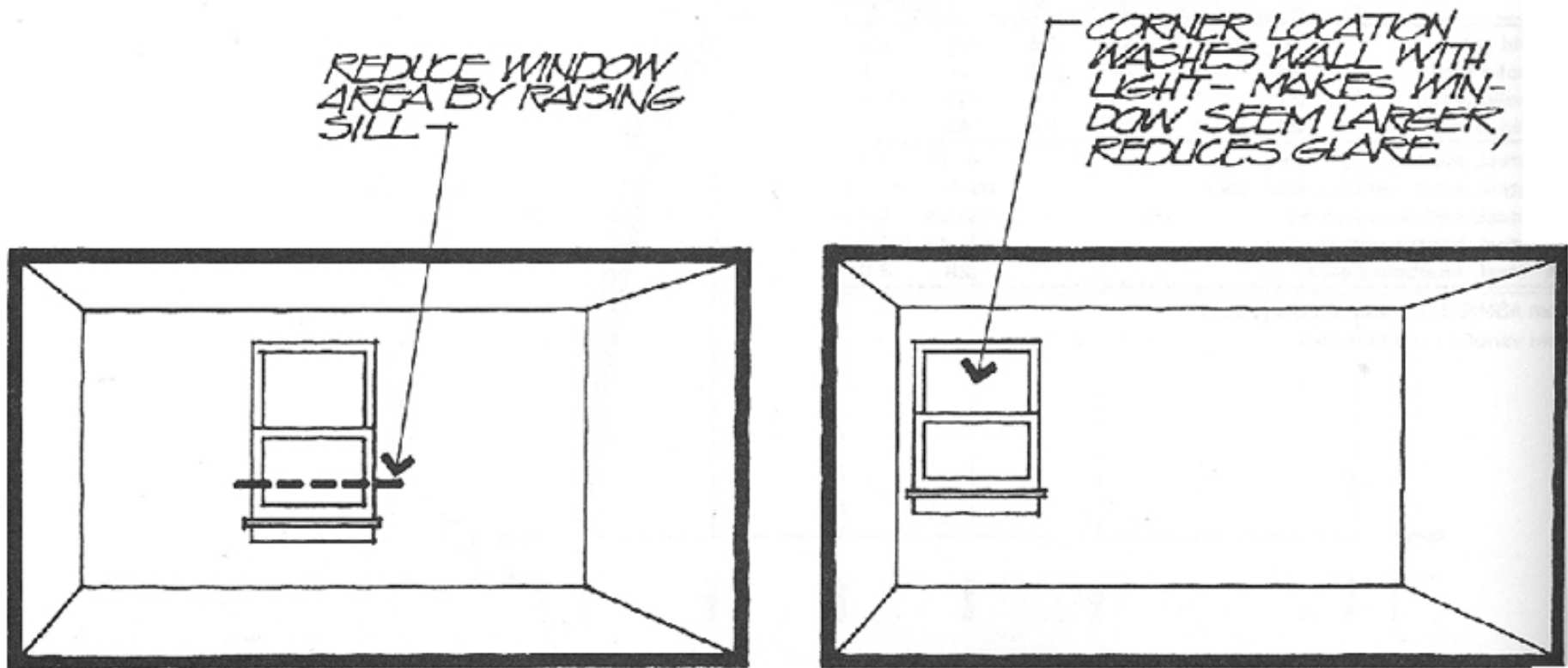

FIG. 40b. When windows must be placed in north, west and east walls, keep the opening small, and use internal placement to best advantage.

TABLE 21a

Suggested room orientations

	N	NE	E	SE	S	SW	W	NW
Bedroom*	•	•	•	•	•			
Bath*	•	•	•	•	•	•	•	•
Kitchen			•	•	•			
Dining			•	•	•	•		
Living				•	•			
Family				•	•	•		
Utility / Laundry*	•	•						•
Workshop*	•	•						•
Storage*	•						•	•
Garage*	•					•	•	•
Sun porch				•	•	•		
Outdoor space*			•	•	•	•		

*The most suitable location of those indicated will depend on local climate — whether largely too hot or too cold, direction of winter winds and summer breezes, etc.

Also a function of relationship to equator and personal preferences.

Visual Comfort

- Visual comfort is taken to mean the absence of physiological pain, irritation or distraction.
- Visual comfort within a space depends on the contrast levels and luminance variations across the space. Glare is one of the most common causes of visual discomfort and can result in the occupant having to interact with the lighting system.
- Occupant interaction with lighting and lighting control systems can significantly impact the energy use patterns of spaces.
- If issues of glare and visual discomfort are understood during the initial design process, they could be designed for and hence affect predicted energy requirements.

The Problem of Glare

Types of Glare Affecting Visual Comfort:

There are two main types of glare.

1. The first occurs when the eye has adapted to an environment over time and the **environment undergoes rapid change**.
2. The other occurs when the eye has adapted to an environment and a **source of light appears that is much brighter** than anything else around it.

The **BORDERLINE**[™]

By Gabe Martin
borderin@cts.com



<http://www.cts.com/~borderin/>

"Bad screen glare, huh Jerry?"

Disability Glare: This is glare which results in a direct reduction in the person's ability to see objects in the field of view. Brilliant light sources, like car headlamps at night, or the view of the sun from a window at the end of a corridor are examples of this sort of discomfort.



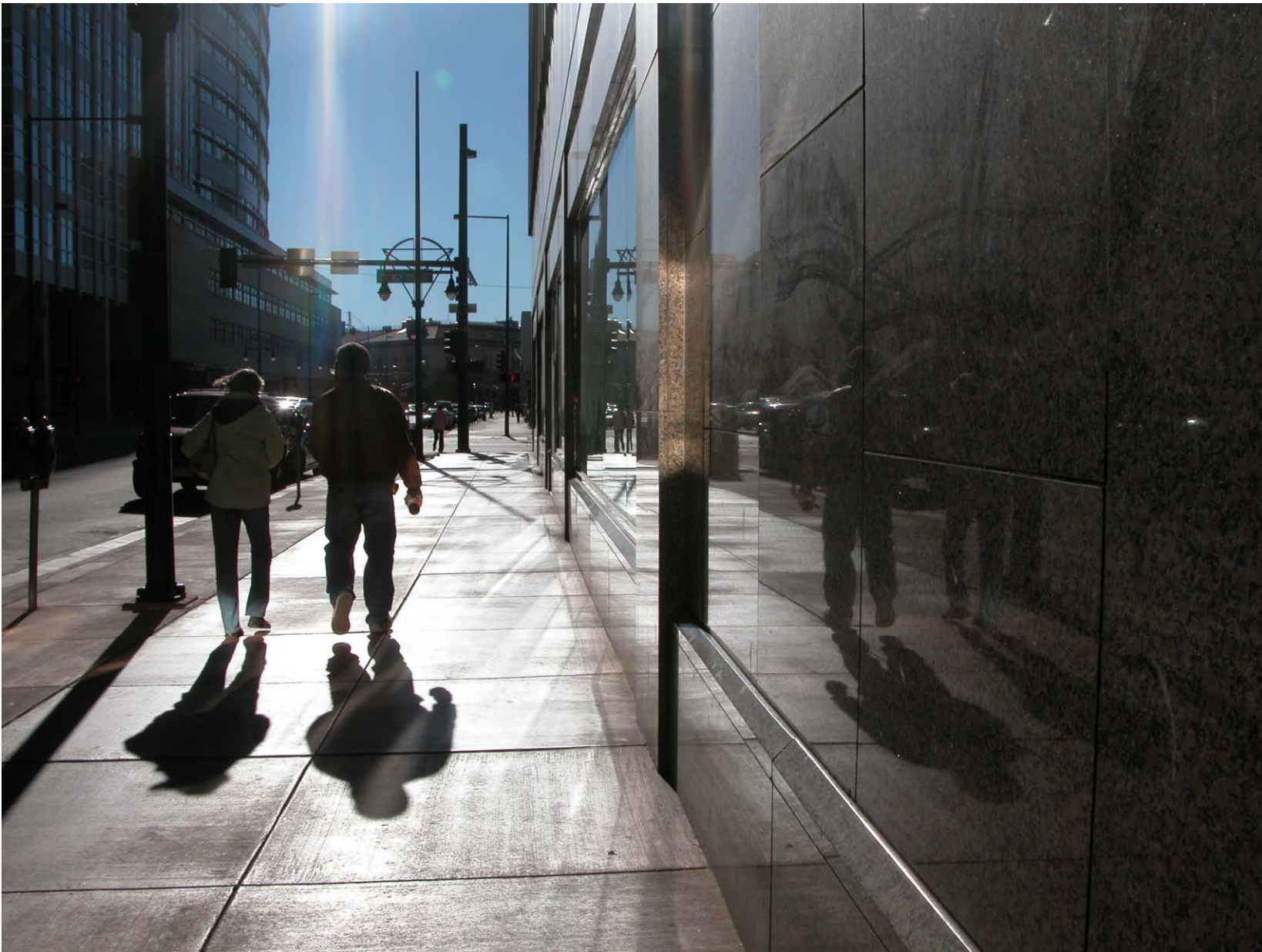

Glare in this instance is also exacerbated by the reflective nature of the sidewalk and curtain wall finishes.

Discomfort Glare: Glare in which there is no significant reduction in the ability to see, although discomfort still persists, due to the bright sources in the field of view is called discomfort glare. e.g. the view of an excessively bright sky near the line of sight of the worker. It might be necessary for the occupant to shade one's eyes with a hand to reduce discomfort.



Veiling Reflections: Veiling reflections are caused when the reflected image of a source of light is brighter than the luminance of the task, e.g. the image of a window or luminaire off the surface of a computer screen. Pencil handwriting where the graphite acts as a mirror is more susceptible to veiling reflections than other types of ink.



Reflected Glare: When light from a light source is reflected off specular surfaces into the eye or field of view, it is called reflected glare. An example would be the discomfort produced by the sun's reflection from a swimming pool.

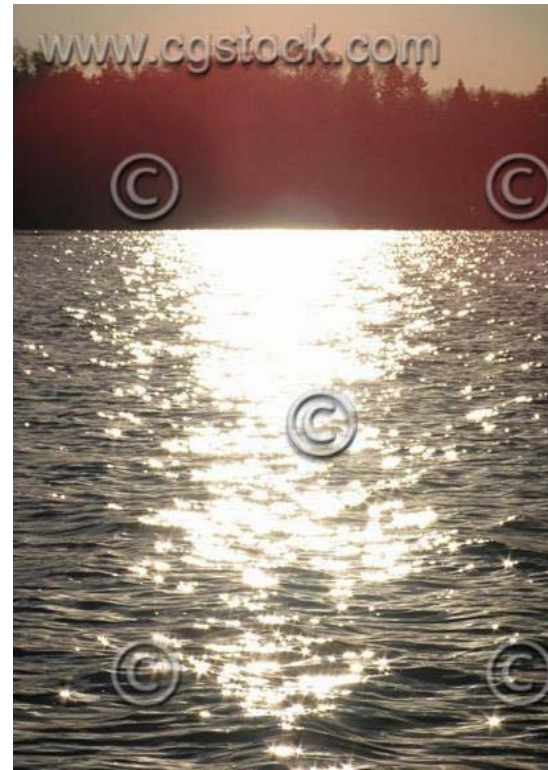
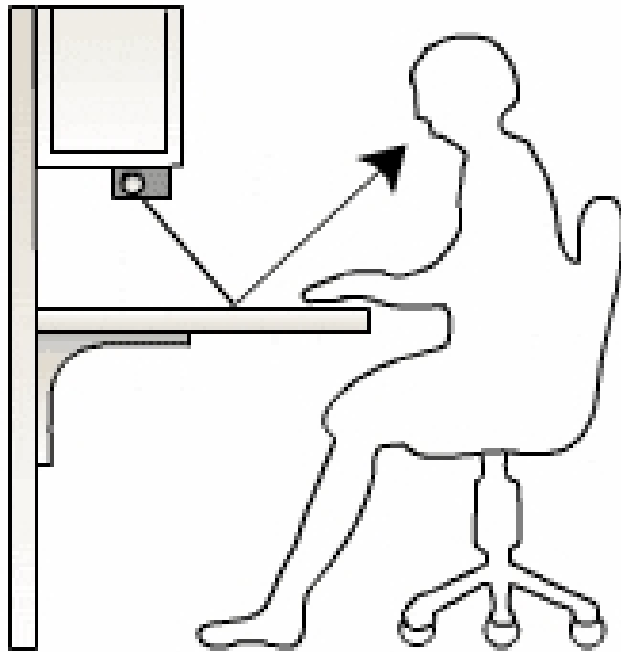

Lightwells and Atriums

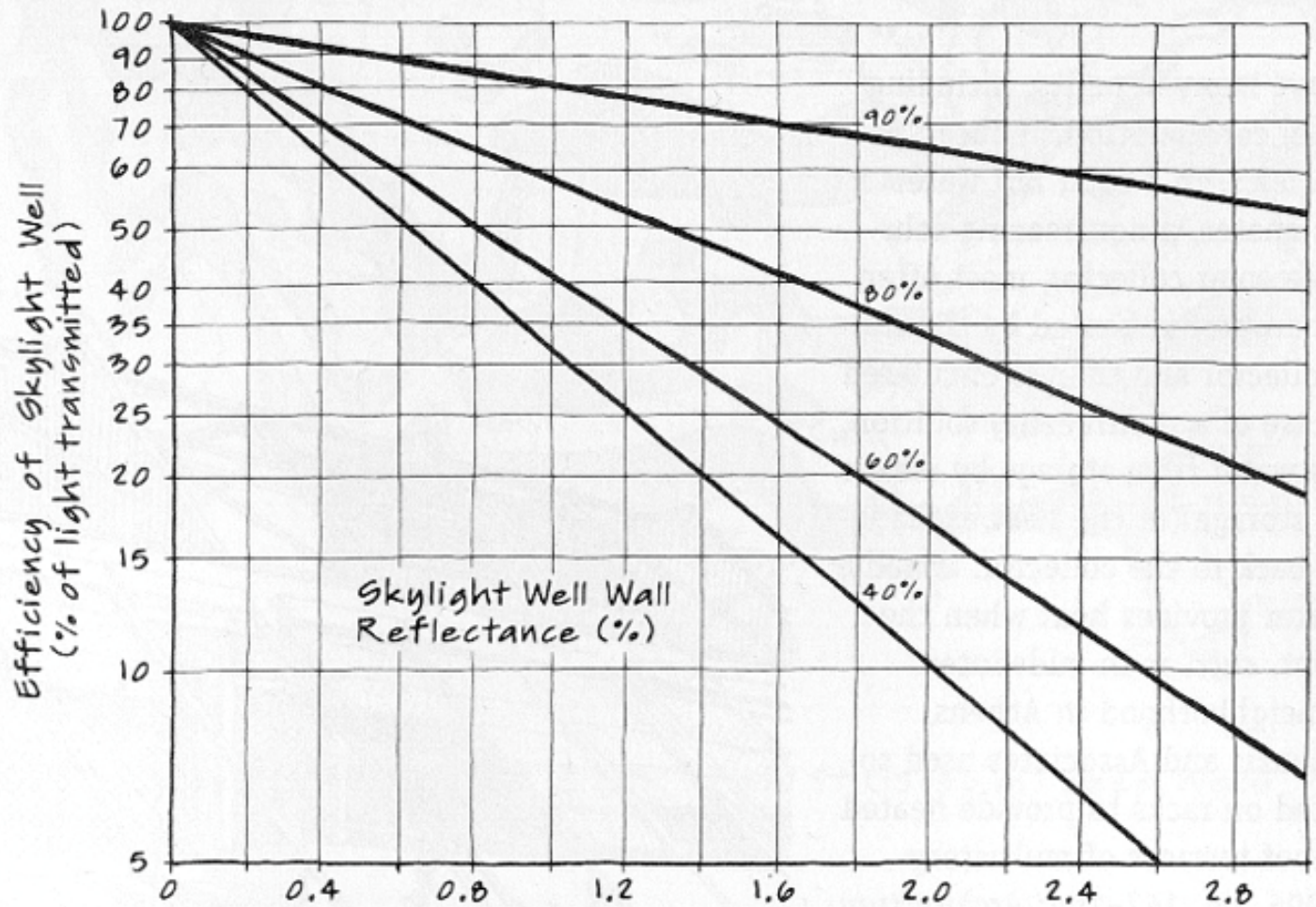

WI=0.25



WI=1.0



WI=1.8

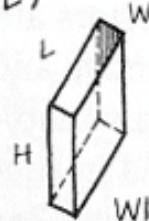

WI=2.5

Sizing and Shaping Light Wells to Transmit Light Efficiently



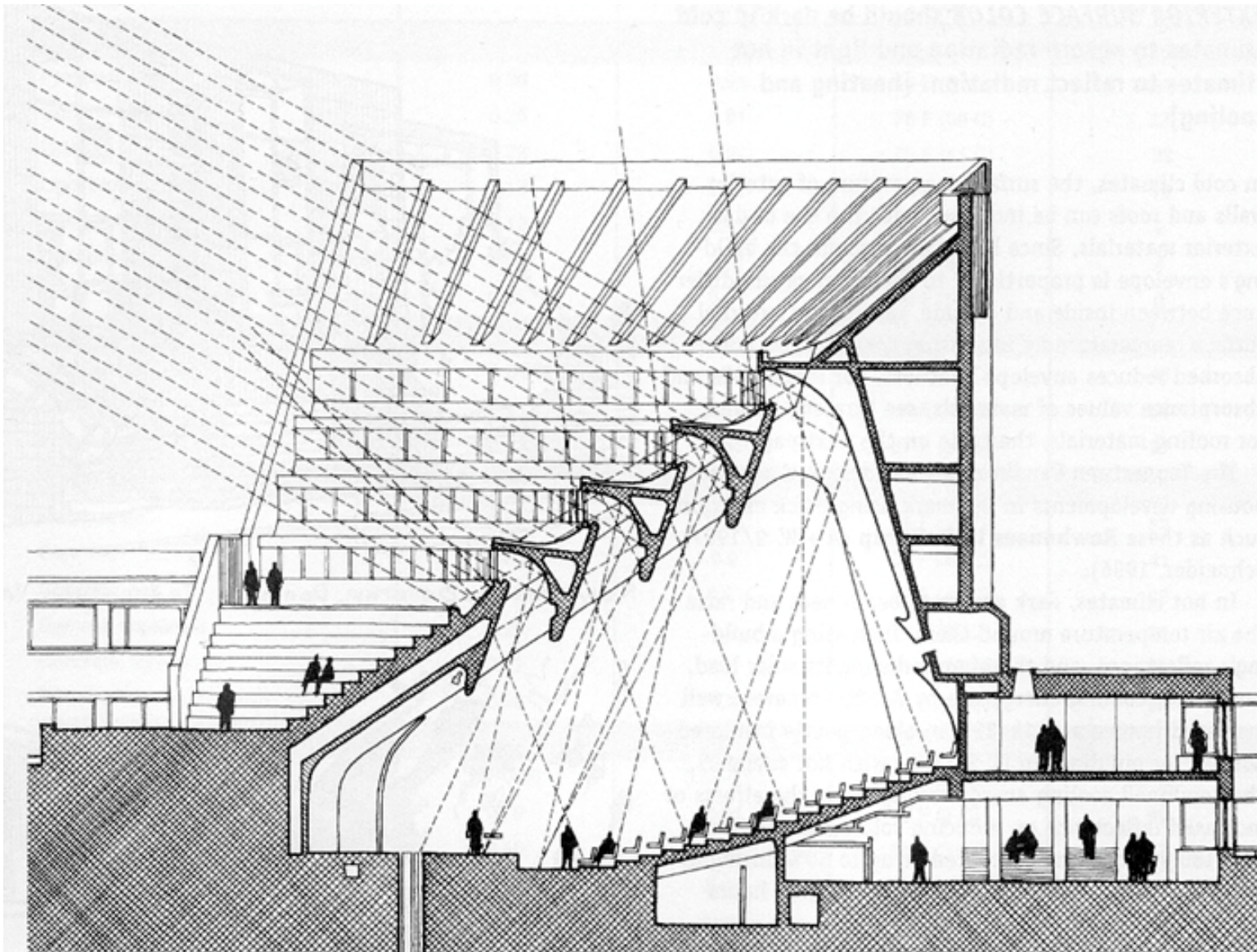

Main Auditorium, Institute of Technology, Otaniemi, Finland, Alvar Aalto

SWL

Lightshelves

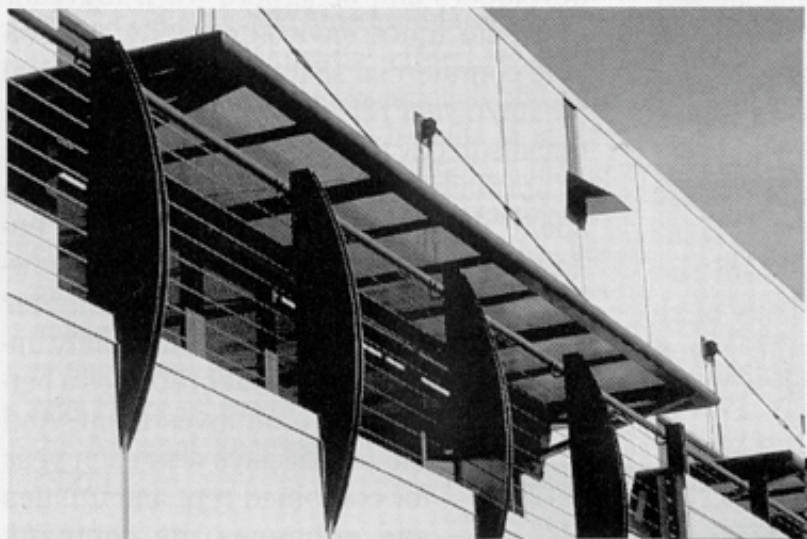

External light shelves shade windows below, minimizing glare and heat gain while reflecting diffused light into the building through glazing above.



Daylighting provides most of the ambient lighting in the building. Tall windows on the long south side, combined with interior light shelves, allow daylight to penetrate deep into the open office space.

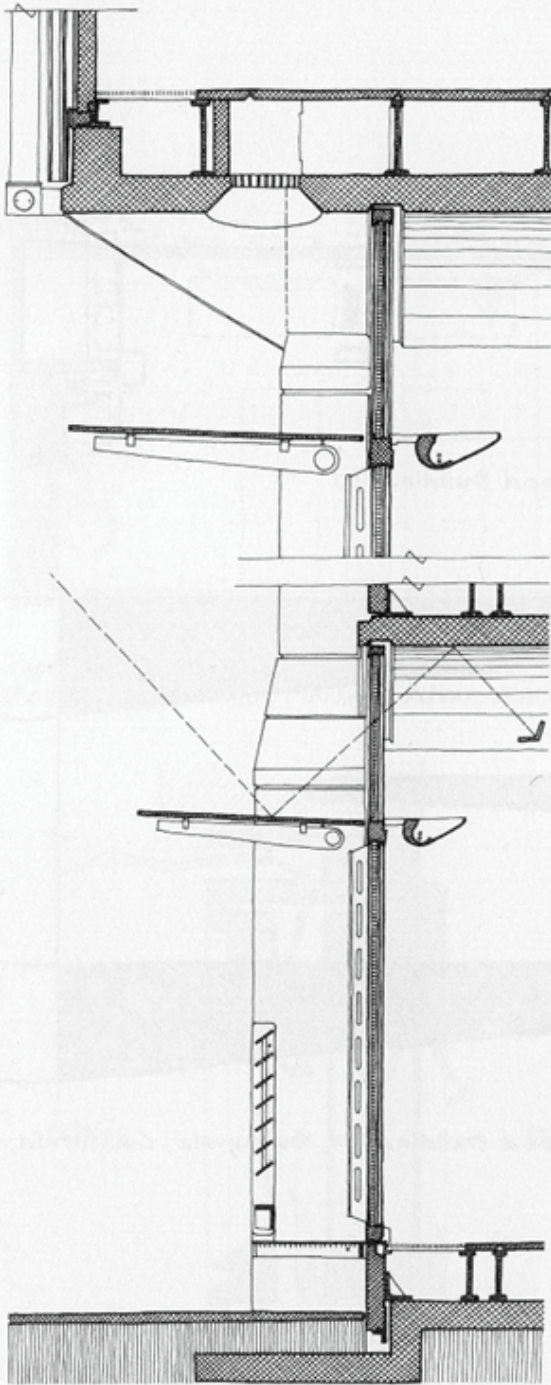

SWL

Inland Revenue Offices, Nottingham, England, Michael Hopkins & Partners

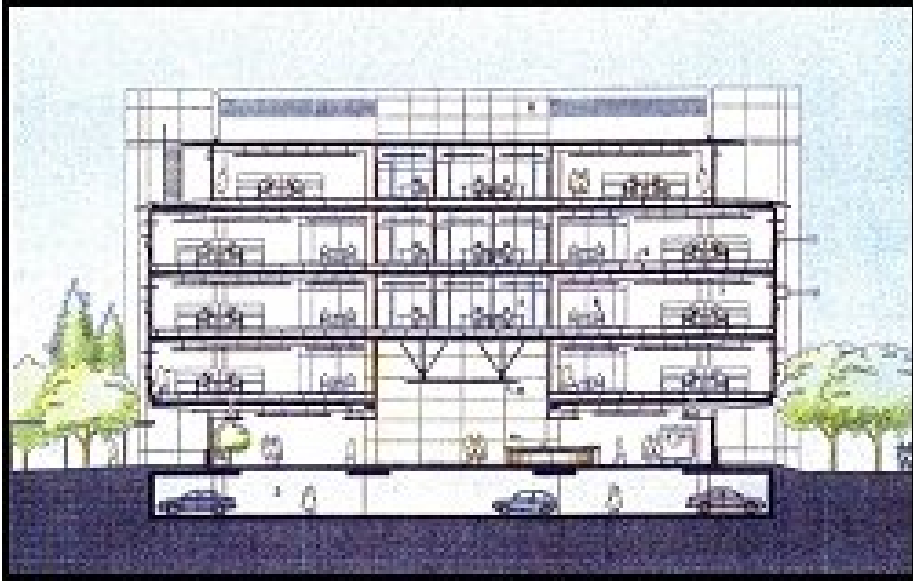

Revenue Canada,
Surrey, B.C.



BC. Gas (Terasen), Surrey, BC



Light shelf designed for BC Gas Operations Centre in Surrey BC.



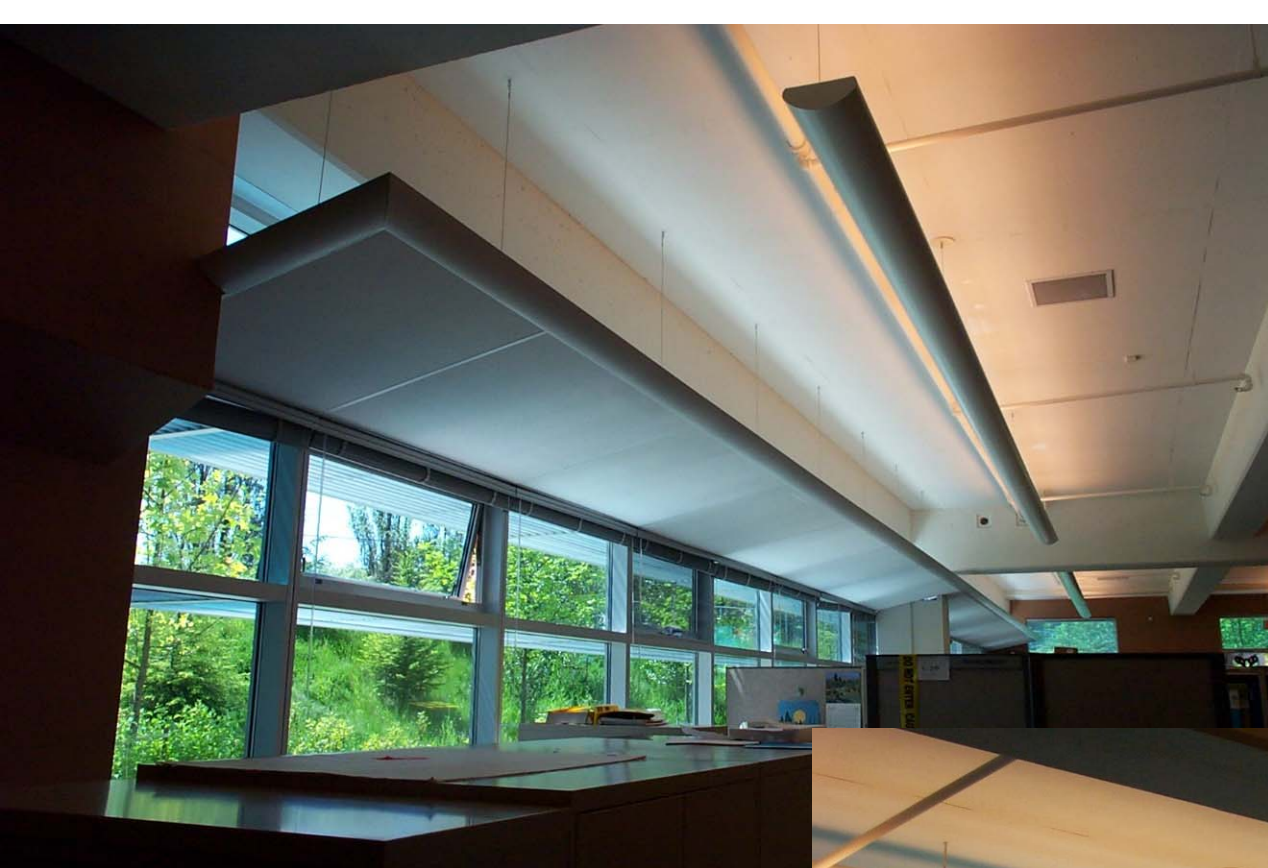

It is interesting to note that the actual images are much darker than the computer renderings of the simulation...



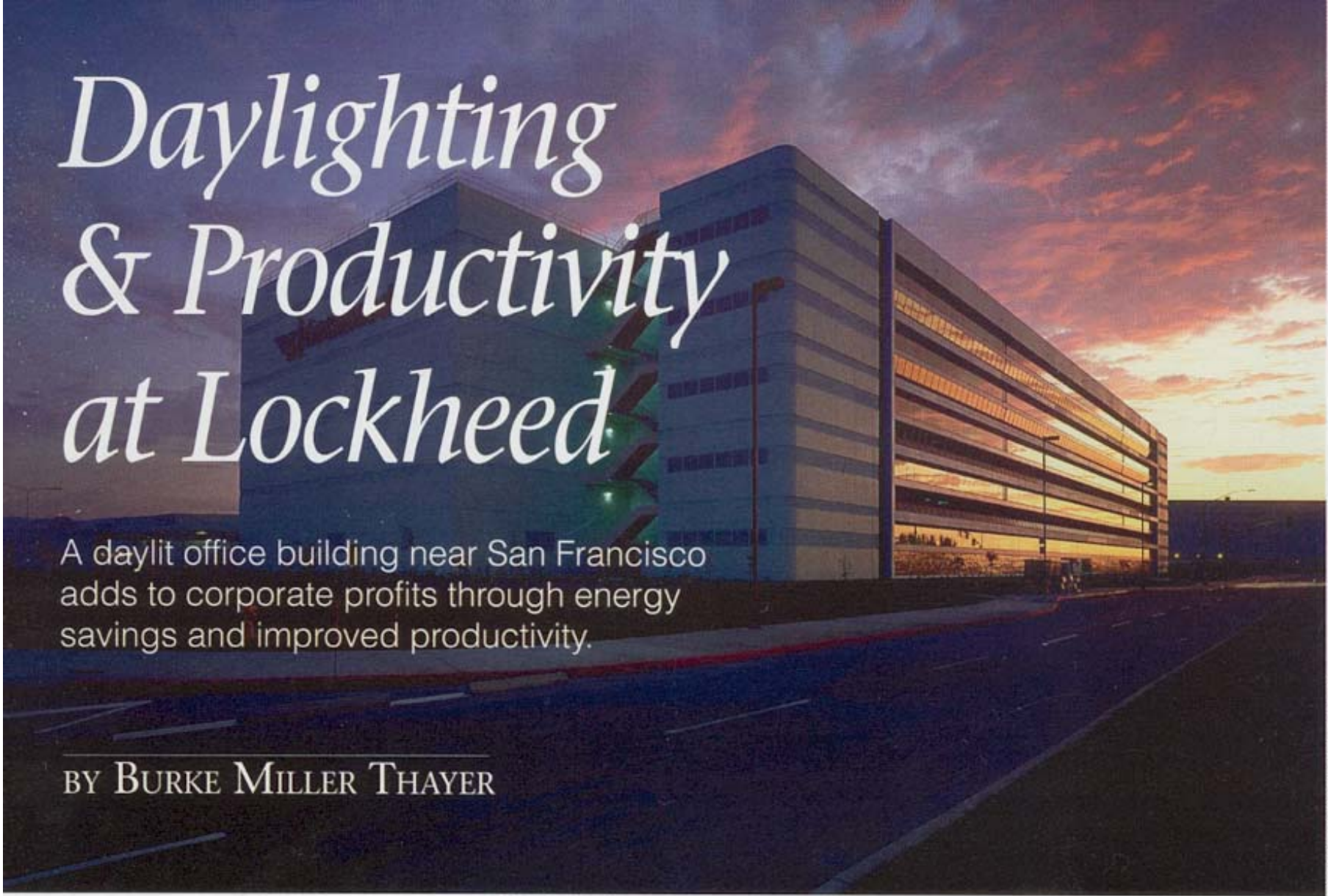

Daylighting & Productivity at Lockheed

A daylit office building near San Francisco adds to corporate profits through energy savings and improved productivity.

BY BURKE MILLER THAYER

This daylit office building in Sunnyvale, California saves Lockheed Martin about \$500,000 each year in energy bills. Higher employee productivity in the building, due largely to the daylighting design, saves even more.

Photography by Timothy Hursley

William D. Browning, Rocky Mountain Institute



High windows above the light shelves allow deep daylight penetration.



Rose Manufacturing Co.

Daylight entering the building reflects off the internal light shelves and the sloped ceiling to provide diffuse ambient lighting deep into the work areas.

Photography by Timothy Hursley



The “litetrium” in the center of the building creates an open, expansive feeling. Daylight from overhead provides ambient lighting for the surrounding office areas.

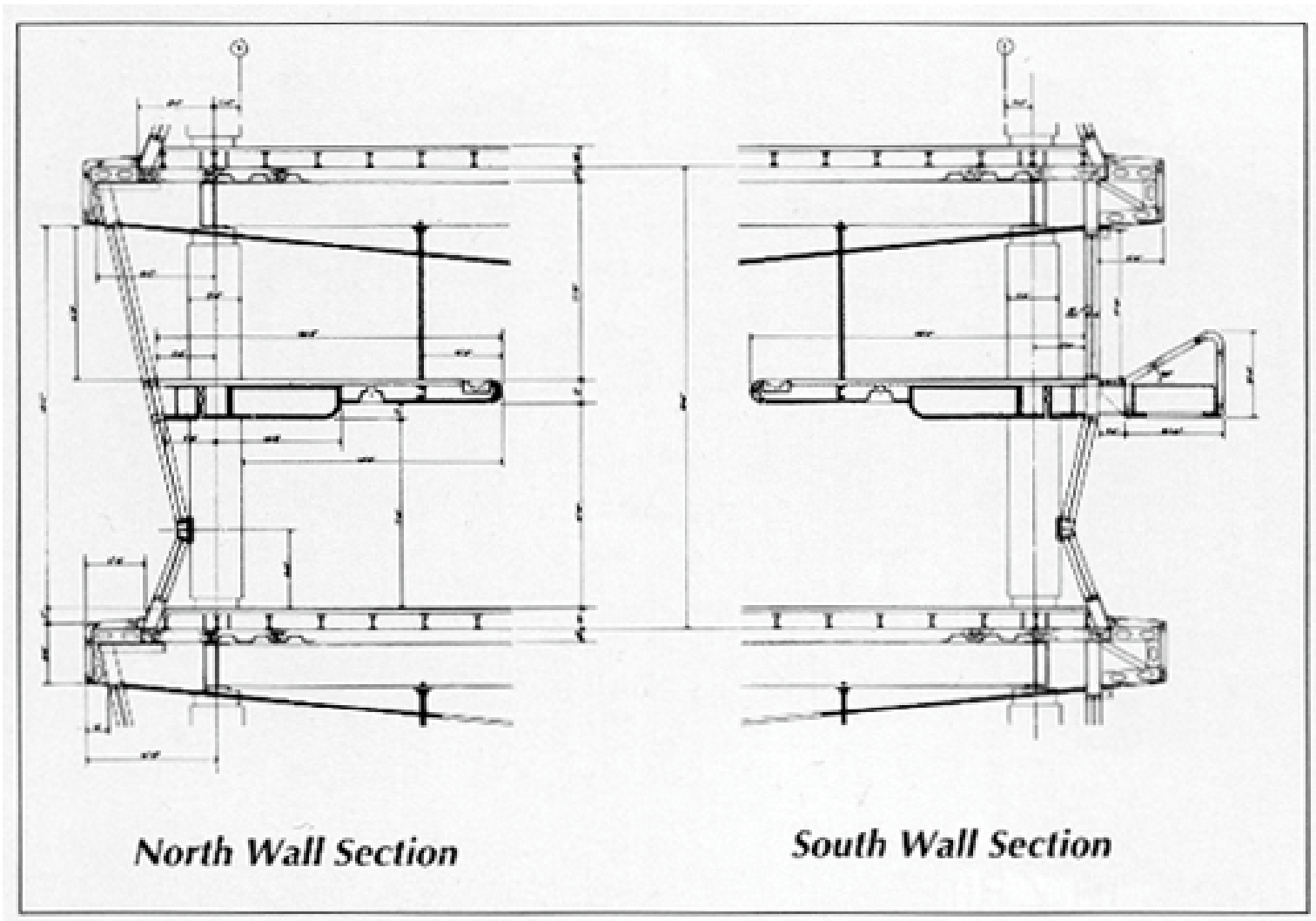

Daylighting and LEED

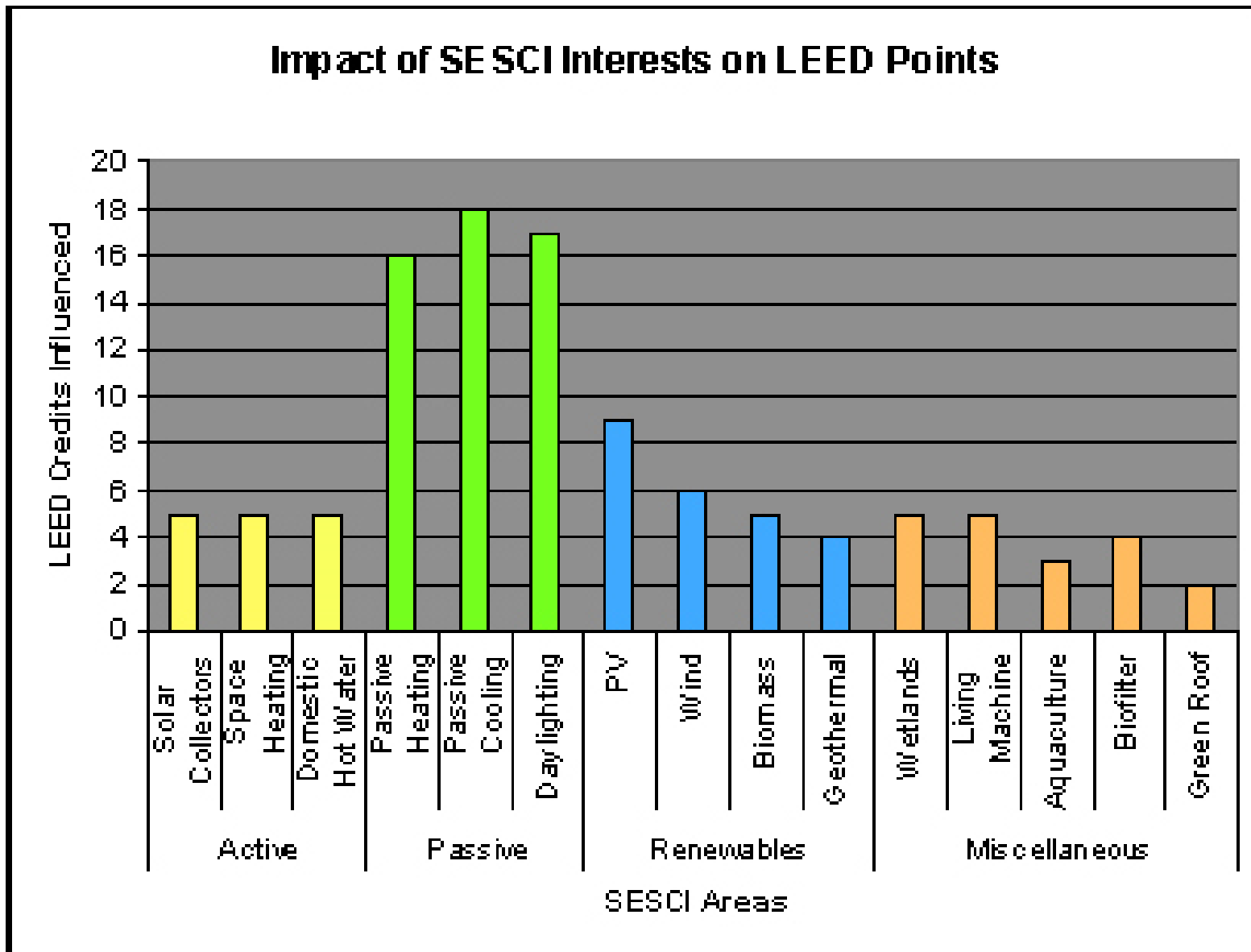

The Impact of Daylight on LEED Credits

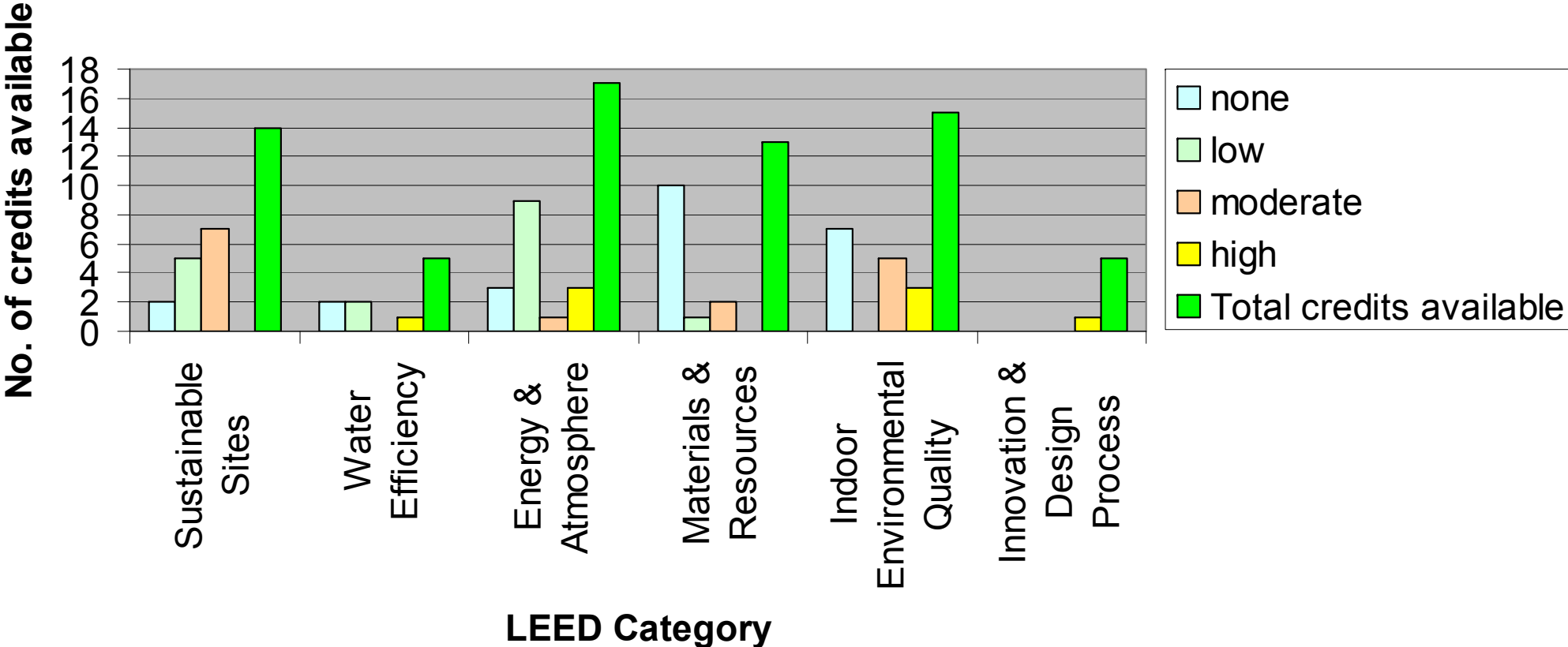

Primary references and image sources for this part of the presentation:

(the two on the right will be available on
the 226 course homepage)

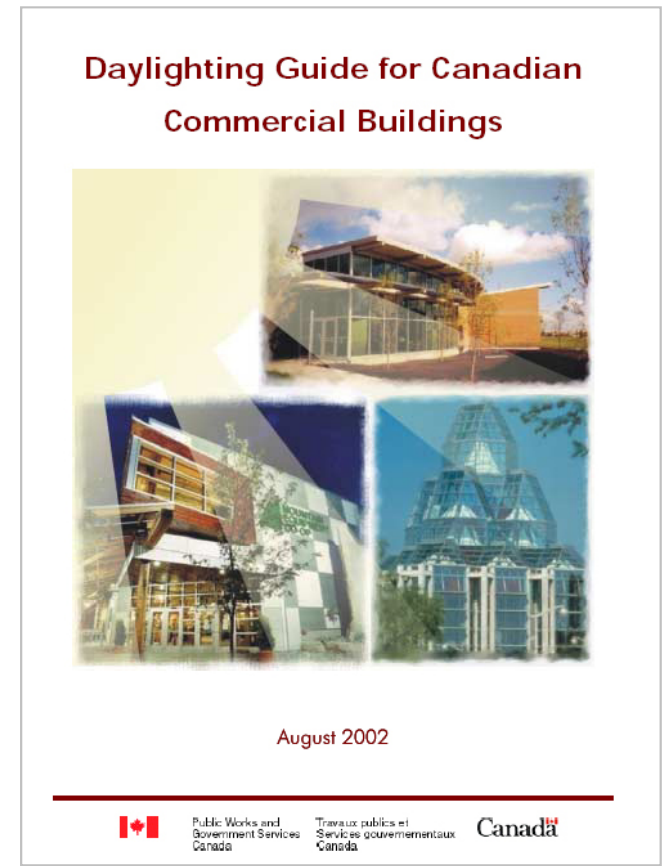
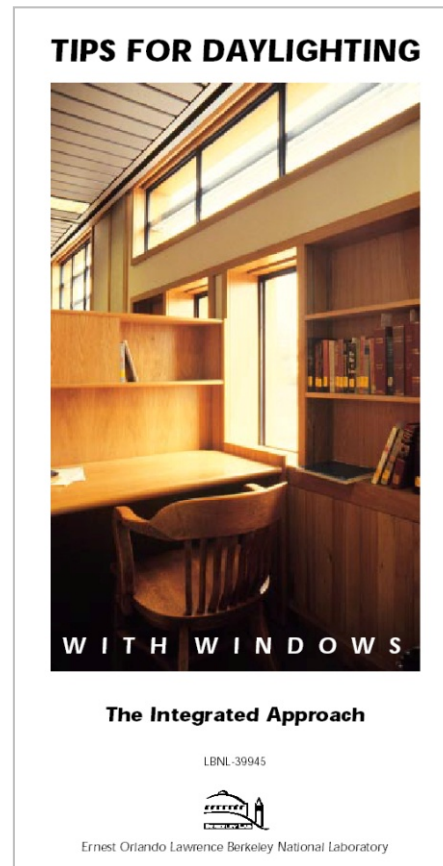
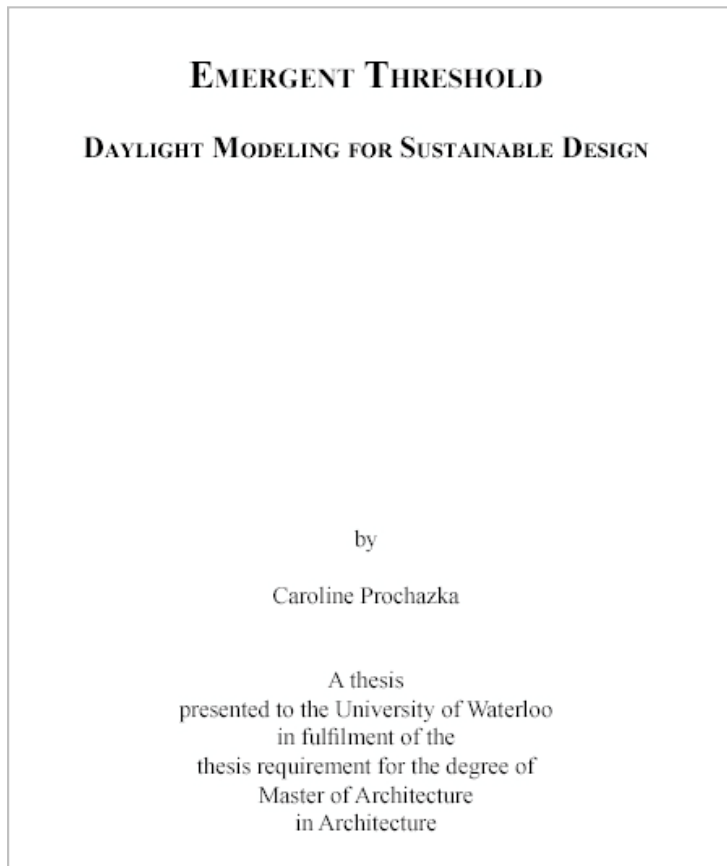

Daylighting – A Canadian Perspective

From the perspective of energy savings, environmental benefit and occupant comfort, daylighting is being increasingly studied and perfected for use in commercial and institutional buildings.

Daylighting Guide for Canadian Commercial Buildings

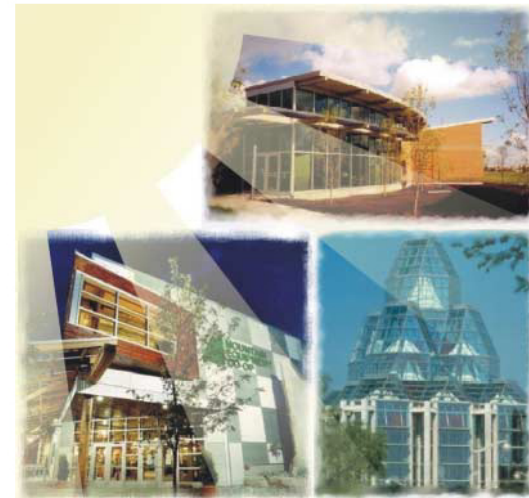

August 2002



Public Works and
Government Services
Canada

Travaux publics et
Services gouvernementaux
Canada

Canada

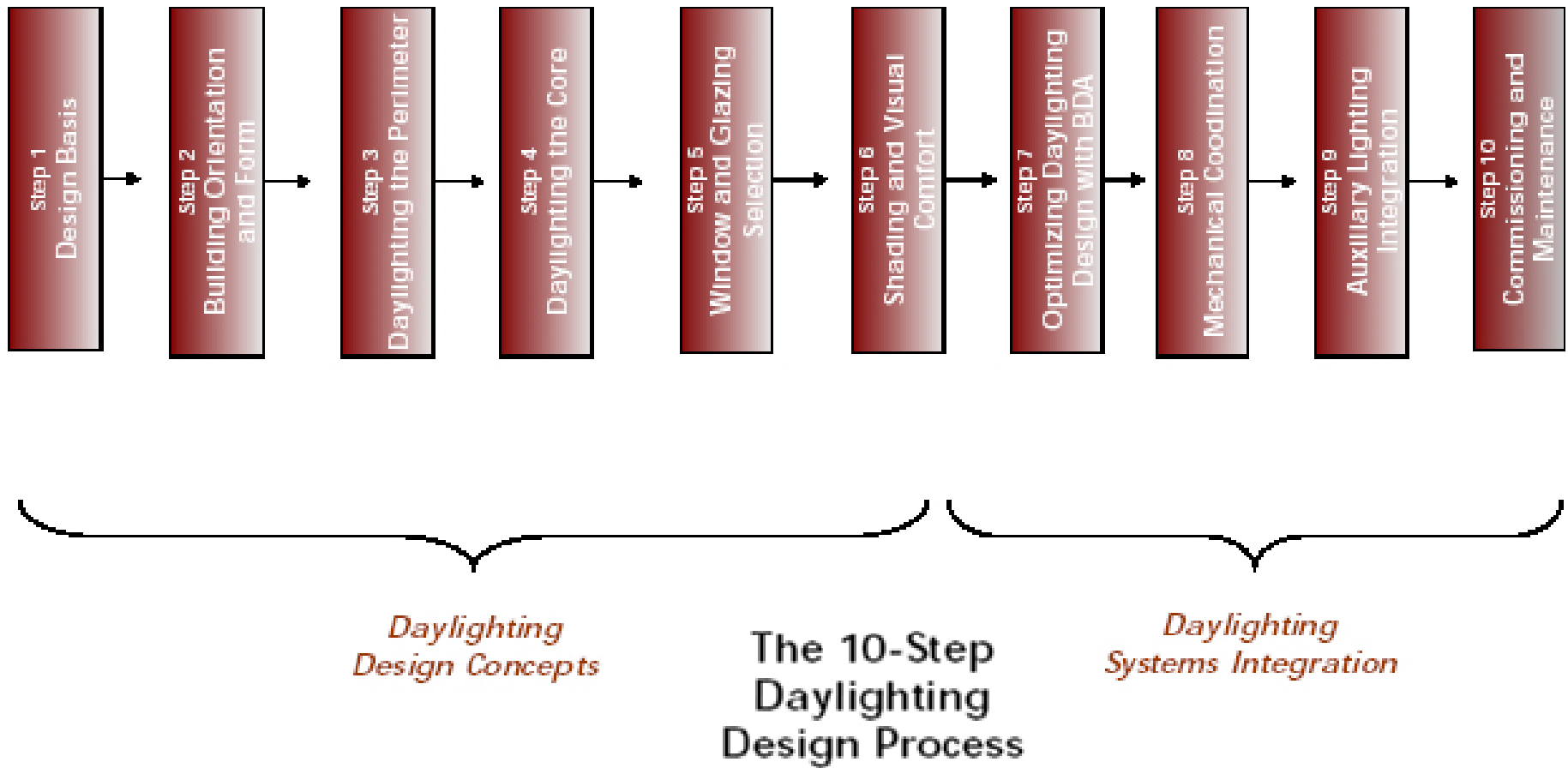

Daylighting for Canadian Buildings divides this into a 10 step process. We will look at steps 1 to 5. We have already studied shading (#6). Steps 8 thru 10 will be addressed in your Lighting and HVAC courses.

Daylight Availability

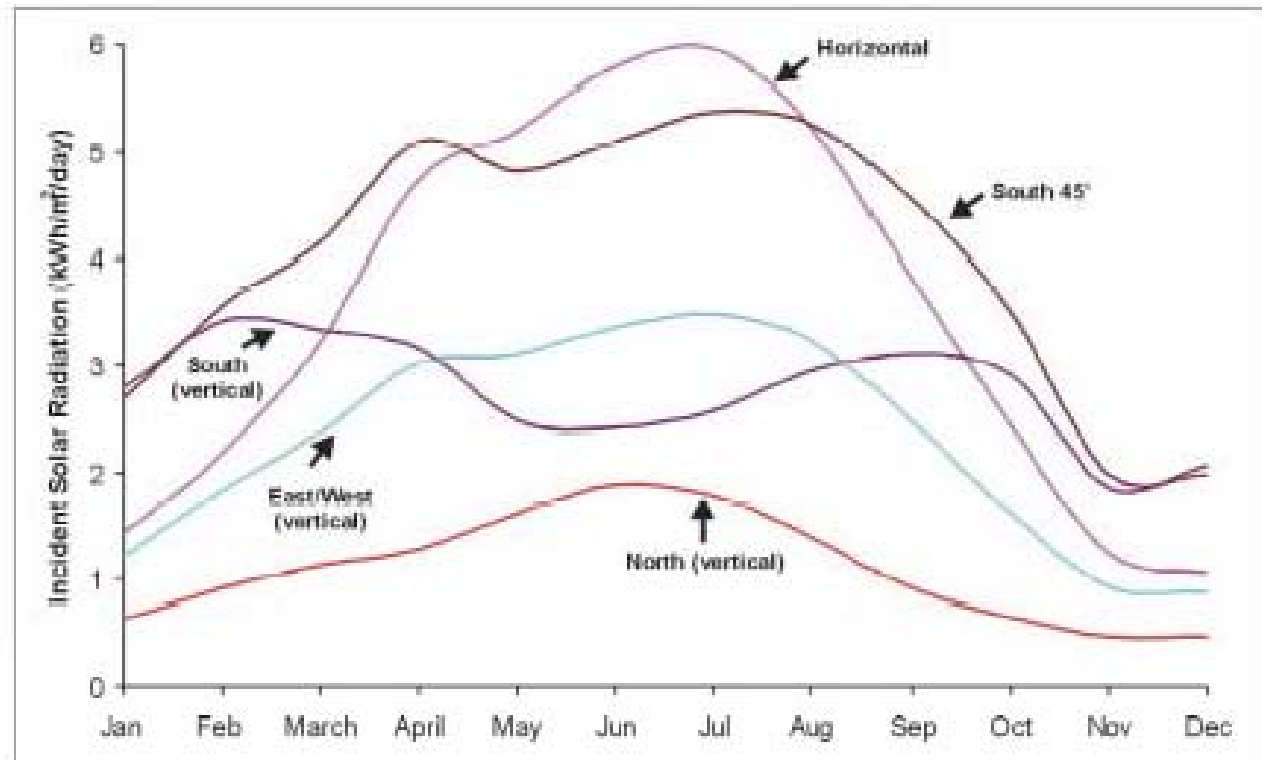

Average Monthly Solar Radiation for Toronto, Ontario

[Source: McKay, 1985]

It is necessary to know the potential daylighting benefit by looking up the solar radiation values for the city in question. Incoming radiation varies based upon orientation (as well as latitude and time of year/day)

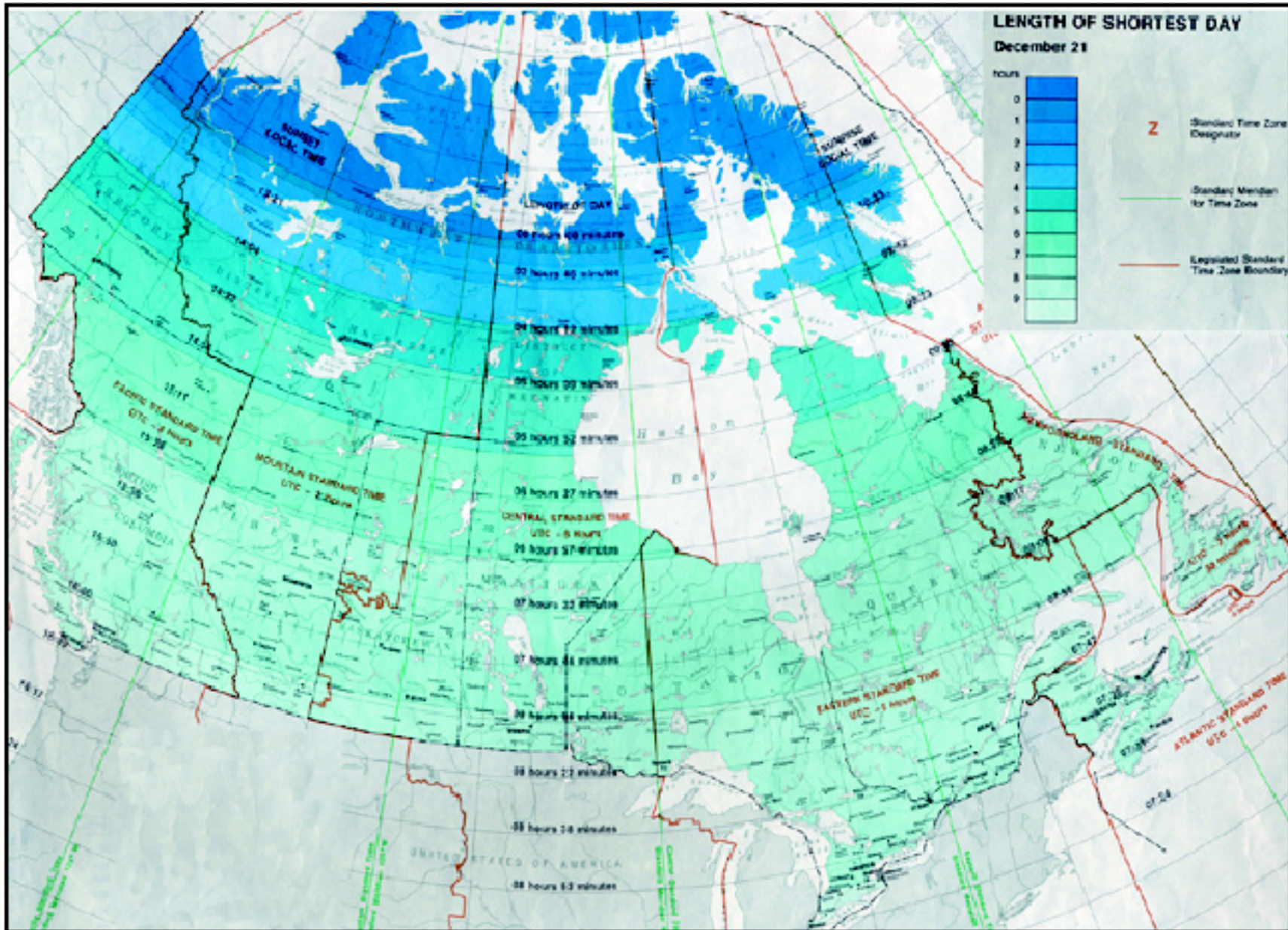

Figure 2.7a. Length of Day Map of Canada for December 21st.

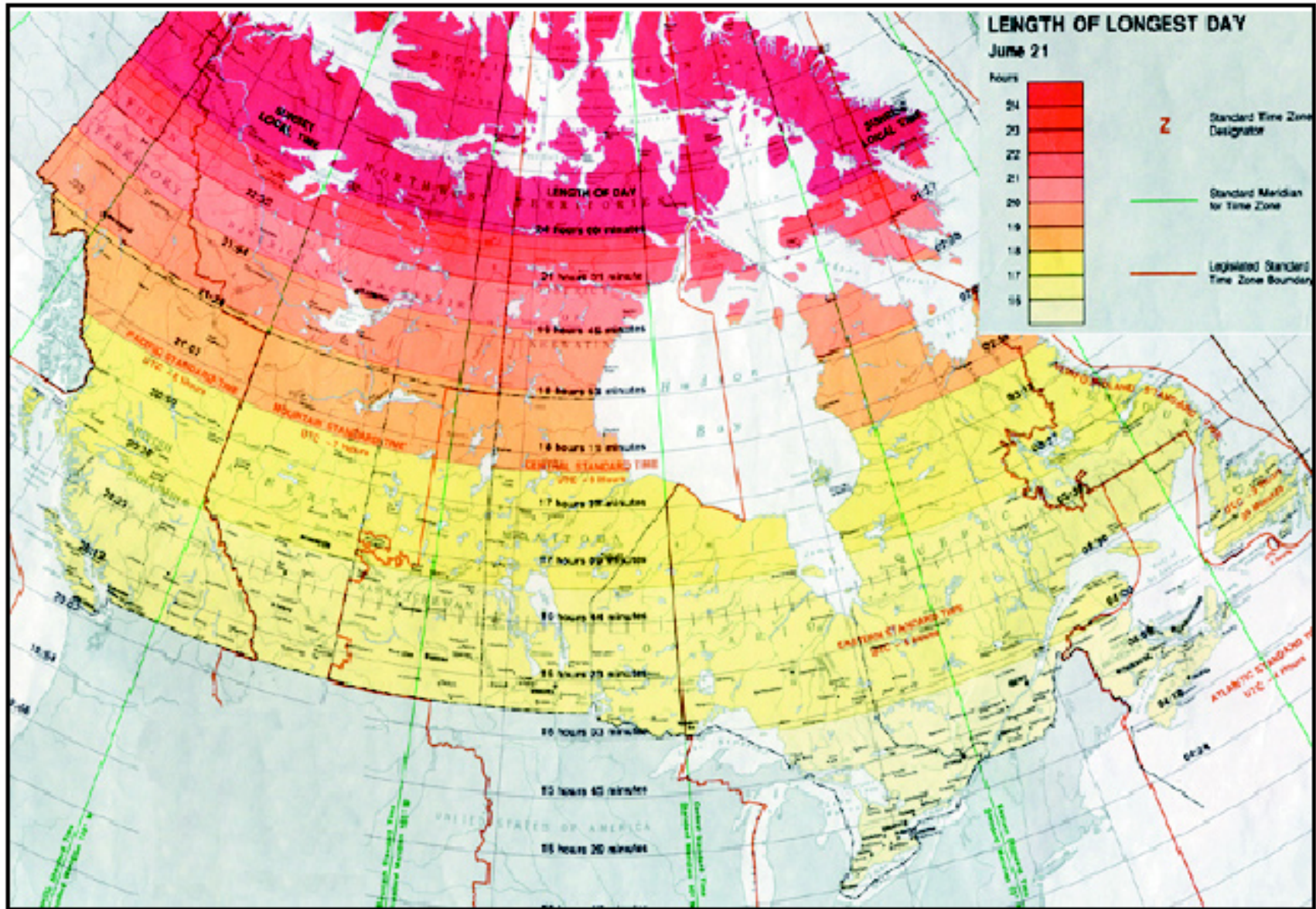

Figure 2.7b. Length of Day Map of Canada for June 21st.

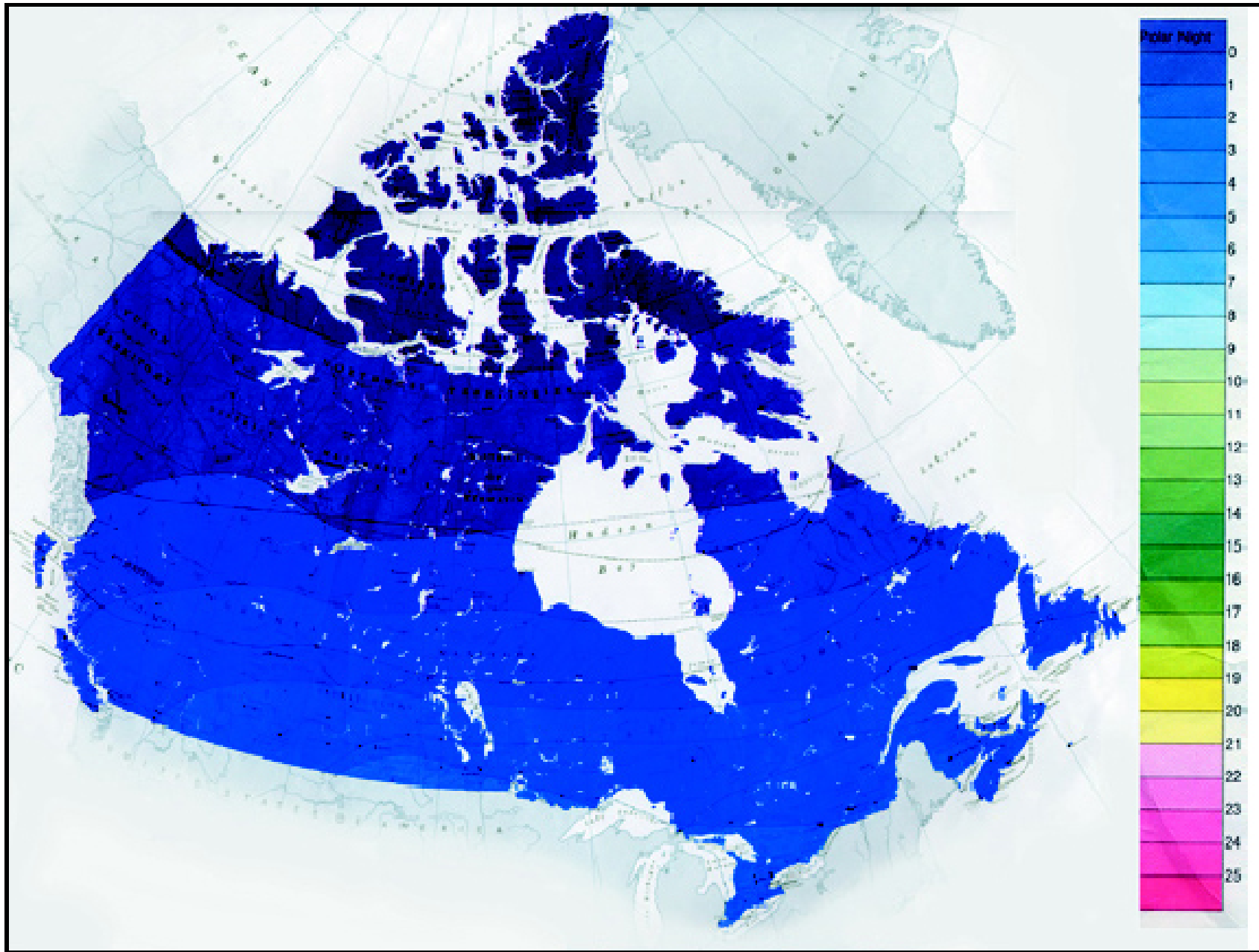

Figure 2.8a. Daily Solar Radiation Map of Canada for December 21st.

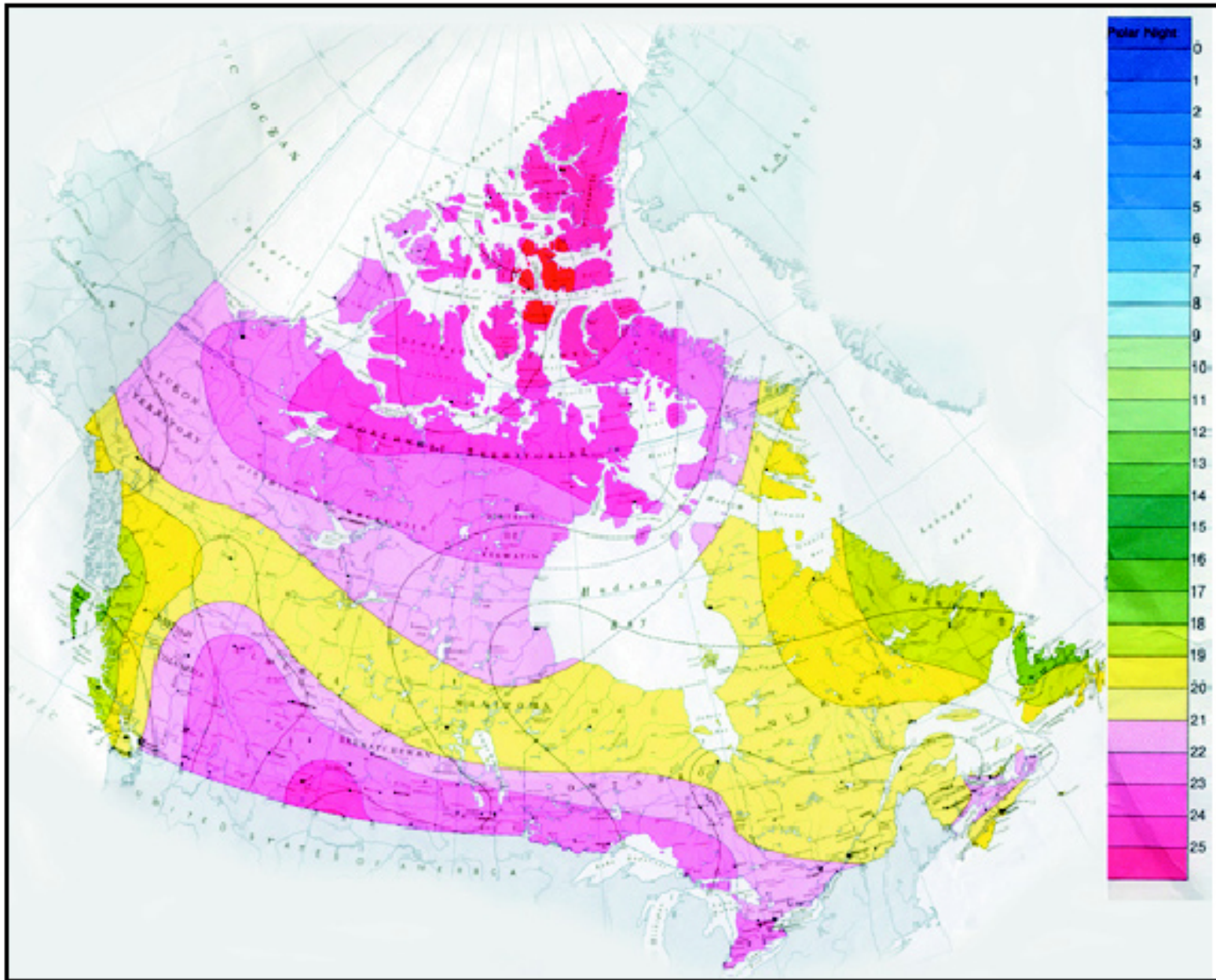

Figure 2.8b. Daily Solar Radiation Map of Canada for June 21st.

WEATHER DATA SUMMARY**LOCATION:** Toronto Int'l, ON, CAN**Latitude/Longitude:** 43.67° North, 79.63° West, **Time Zone from Greenwich** -5**Data Source:** WYEC2-B-04714 716240 WMO Station Number, **Elevation** 567 ft

MONTHLY MEANS	JAN	FEB	MAR	APR	MAY	JUN	JUL	AUG	SEP	OCT	NOV	DEC	
Global Horiz Radiation (Avg Hourly)	51	70	85	104	121	128	128	119	105	75	43	38	Btu/sq.ft
Direct Normal Radiation (Avg Hourly)	72	84	85	97	103	102	114	100	110	79	41	54	Btu/sq.ft
Diffuse Radiation (Avg Hourly)	27	35	40	45	54	58	52	56	44	40	27	21	Btu/sq.ft
Global Horiz Radiation (Max Hourly)	150	206	277	295	308	317	310	287	262	207	163	132	Btu/sq.ft
Direct Normal Radiation (Max Hourly)	278	300	323	325	304	300	293	295	295	275	272	276	Btu/sq.ft
Diffuse Radiation (Max Hourly)	75	116	139	136	188	172	145	136	122	103	79	61	Btu/sq.ft
Global Horiz Radiation (Avg Daily Total)	465	717	1008	1378	1775	1945	1913	1636	1299	814	412	340	Btu/sq.ft
Direct Normal Radiation (Avg Daily Total)	665	856	1016	1281	1498	1559	1706	1374	1347	844	396	481	Btu/sq.ft
Diffuse Radiation (Avg Daily Total)	248	364	477	602	796	893	773	777	553	430	259	187	Btu/sq.ft
Global Horiz Illumination (Avg Hourly)	1676	2322	2824	3453	4045	4258	4254	3967	3500	2524	1446	1271	footcandles
Direct Normal Illumination (Avg Hourly)	2097	2510	2632	3010	3188	3165	3526	3103	3372	2391	1241	1596	footcandles
Dry Bulb Temperature (Avg Monthly)	21	21	30	42	53	63	69	67	58	47	38	27	degrees F
Dew Point Temperature (Avg Monthly)	16	15	23	32	39	52	58	57	50	39	33	22	degrees F
Relative Humidity (Avg Monthly)	78	75	74	70	62	68	70	70	75	77	83	79	percent
Wind Direction (Monthly Mode)	250	270	270	90	340	0	330	340	330	250	250	250	degrees
Wind Speed (Avg Monthly)	9	11	12	10	9	8	7	4	7	9	9	12	mph
Ground Temperature (Avg Monthly of 3 Depths)	31	29	30	33	42	51	57	60	59	54	46	38	degrees F

Back

Next

MONTHLY DIURNAL AVERAGES

LOCATION: Toronto Int'l, ON, CAN
Latitude/Longitude: 43.67° North, 79.63° West, **Time Zone from Greenwich** -5
Data Source: WYEC2-B-04714 716240 WMO Station Number, **Elevation** 567 ft

LEGEND

HOURLY AVERAGES

TEMPERATURE: (degrees F)

- DRY BULB MEAN
- WET BULB MEAN
- █ DRY BULB (hourly)
- █ COMFORT ZONE

RADIATION: (Btu/sq.ft)

- █ GLOBAL HORIZ
- █ DIRECT NORMAL
- █ DIFFUSE

Display Hourly Dry Bulb Temp

TEMPERATURE RANGE:

10 to 110 °F

Fit to Data

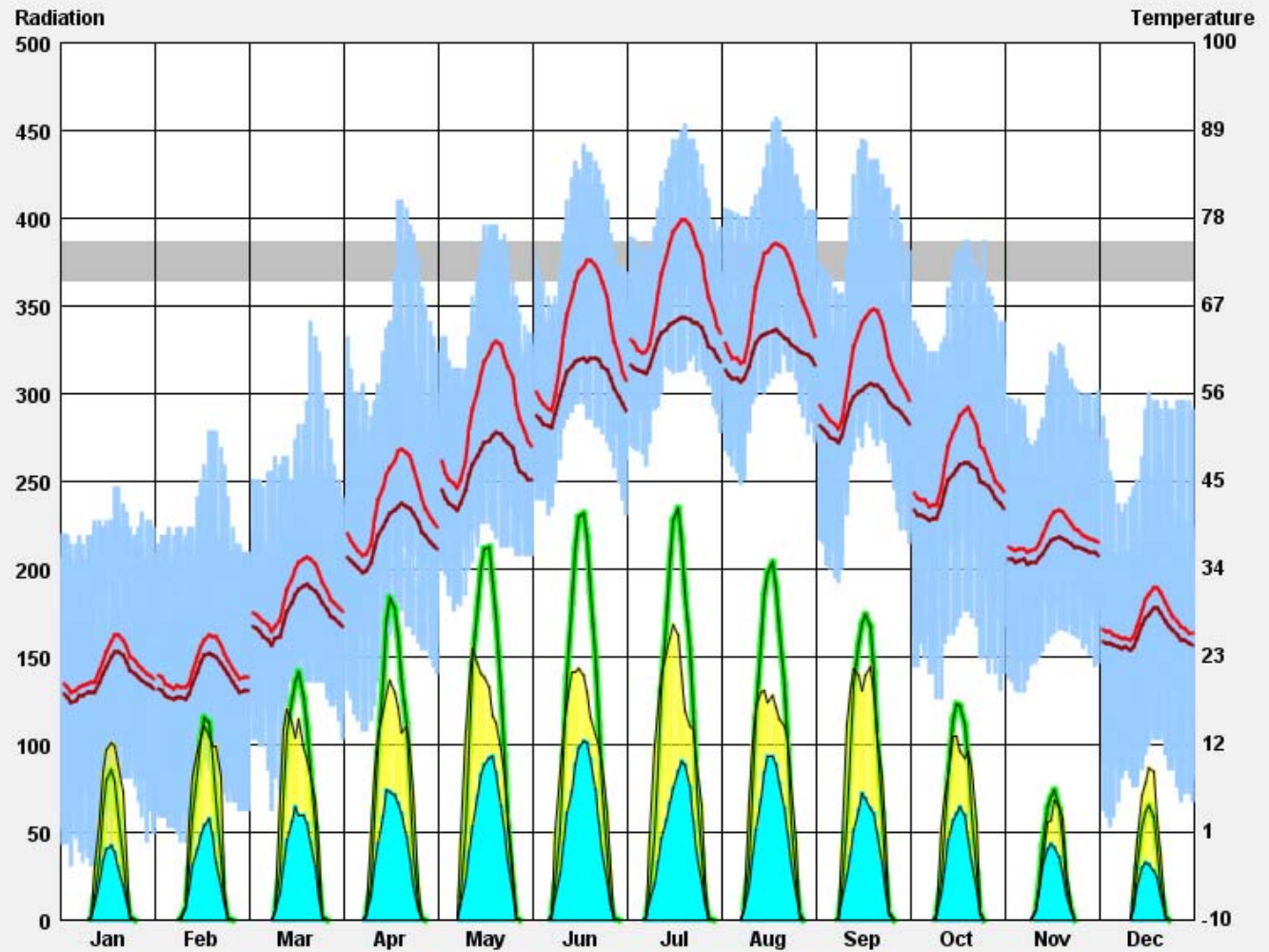

Back



Next

RADIATION RANGE

LOCATION: Toronto Int'l, ON, CAN
Latitude/Longitude: 43.67° North, 79.63° West, **Time Zone from Greenwich** -5
Data Source: WYEC2-B-04714 716240 WMO Station Number, **Elevation** 567 ft

LEGEND

**DAILY TOTALS
DAYLIT HOURS ONLY**

RECORDED HIGH - 
 MEAN - 
 RECORDED LOW - 

RECORDED:
 **DIRECT NORMAL**
 **GLOBAL HORIZONTAL**
 **TOTAL SURFACE**
 (Btu/sq.ft per day)

Tilted Surface Radiation Input:
 Tilt degrees from Horizontal
 (Vertical = 90°)
 Bearing degrees from South
 (South = 0°, West = +90°)
 % Ground Reflectance
 (20% = grass)

PLOT:
 Hourly Avg Daily Total

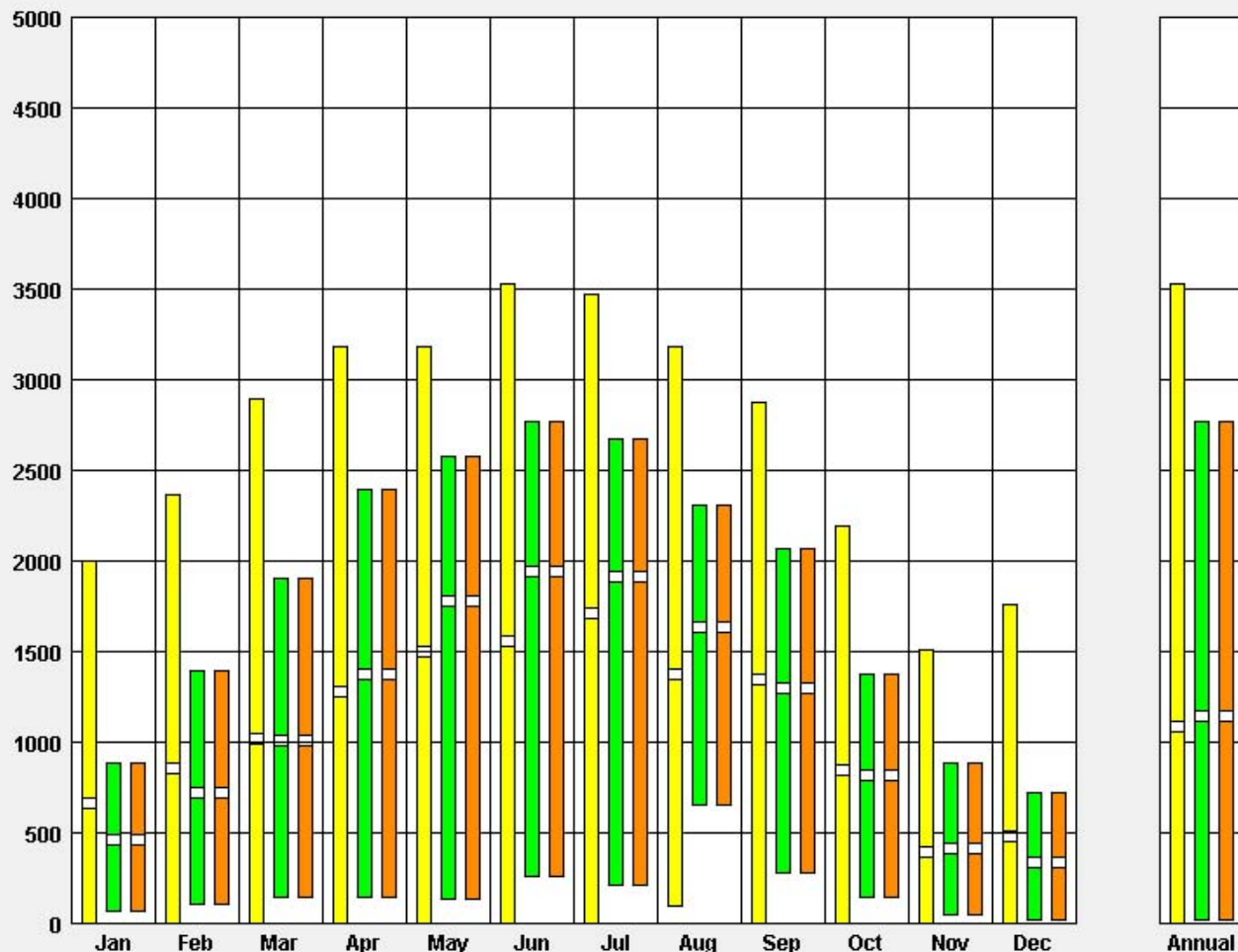

Hit ENTER to replot if you change Tilted Surface Radiation parameters.

Back

Next

RADIATION RANGE

LOCATION: Toronto Int'l, ON, CAN
Latitude/Longitude: 43.67° North, 79.63° West, **Time Zone from Greenwich** -5
Data Source: WYEC2-B-04714 716240 WMO Station Number, **Elevation** 567 ft

LEGEND

**HOURLY AVERAGES
DAYLIT HOURS ONLY**

- RECORDED HIGH - ○
- AVERAGE HIGH -
- MEAN -
- AVERAGE LOW -
- RECORDED LOW - ○

RECORDED:

- DIRECT NORMAL
- GLOBAL HORIZONTAL
- TOTAL SURFACE
(Btu/sq.ft per hour)

THEORETICAL:

-

Tilted Surface Radiation Input:

- Tilt degrees from Horizontal
(Vertical = 90°)
- Bearing degrees from South
(South = 0°, West = +90°)
- % Ground Reflectance
(20% = grass)

PLOT:

- Hourly Avg
- Daily Total

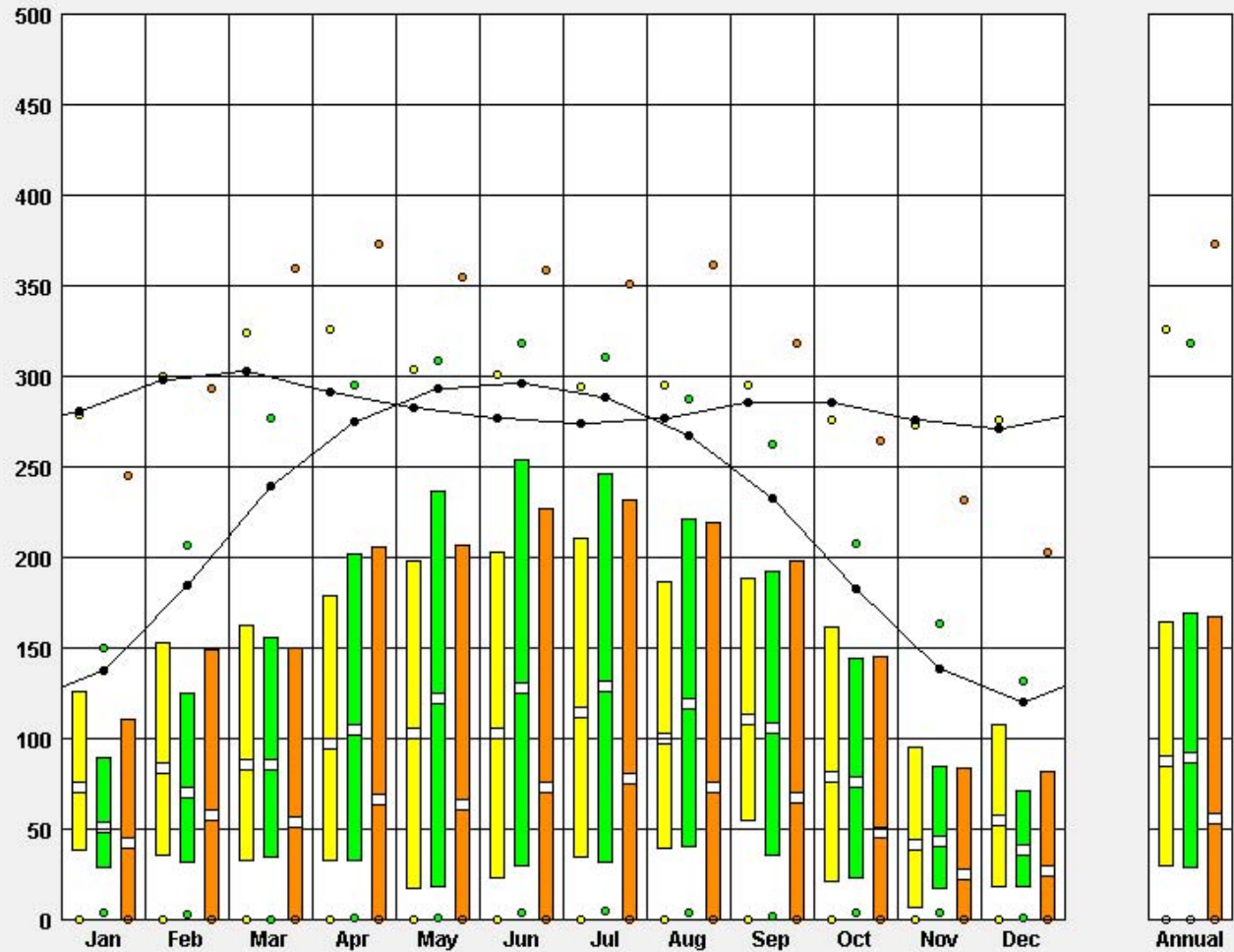

Hit ENTER to replot if you change Tilted Surface Radiation parameters.

Back Next

ILLUMINATION RANGE

LOCATION: Toronto Int'l, ON, CAN
Latitude/Longitude: 43.67° North, 79.63° West, **Time Zone from Greenwich** -5
Data Source: WYEC2-B-04714 716240 WMO Station Number, **Elevation** 567 ft

LEGEND

**HOURLY ILLUMINATION
DAYLIT HOURS ONLY**

- RECORDED HIGH - ○
- AVERAGE HIGH - [Yellow bar]
- MEAN - [White bar]
- AVERAGE LOW - [Yellow bar]
- RECORDED LOW - ○

RECORDED:

- [Yellow bar] DIRECT NORMAL
- [Green bar] GLOBAL HORIZONTAL
(footcandles)

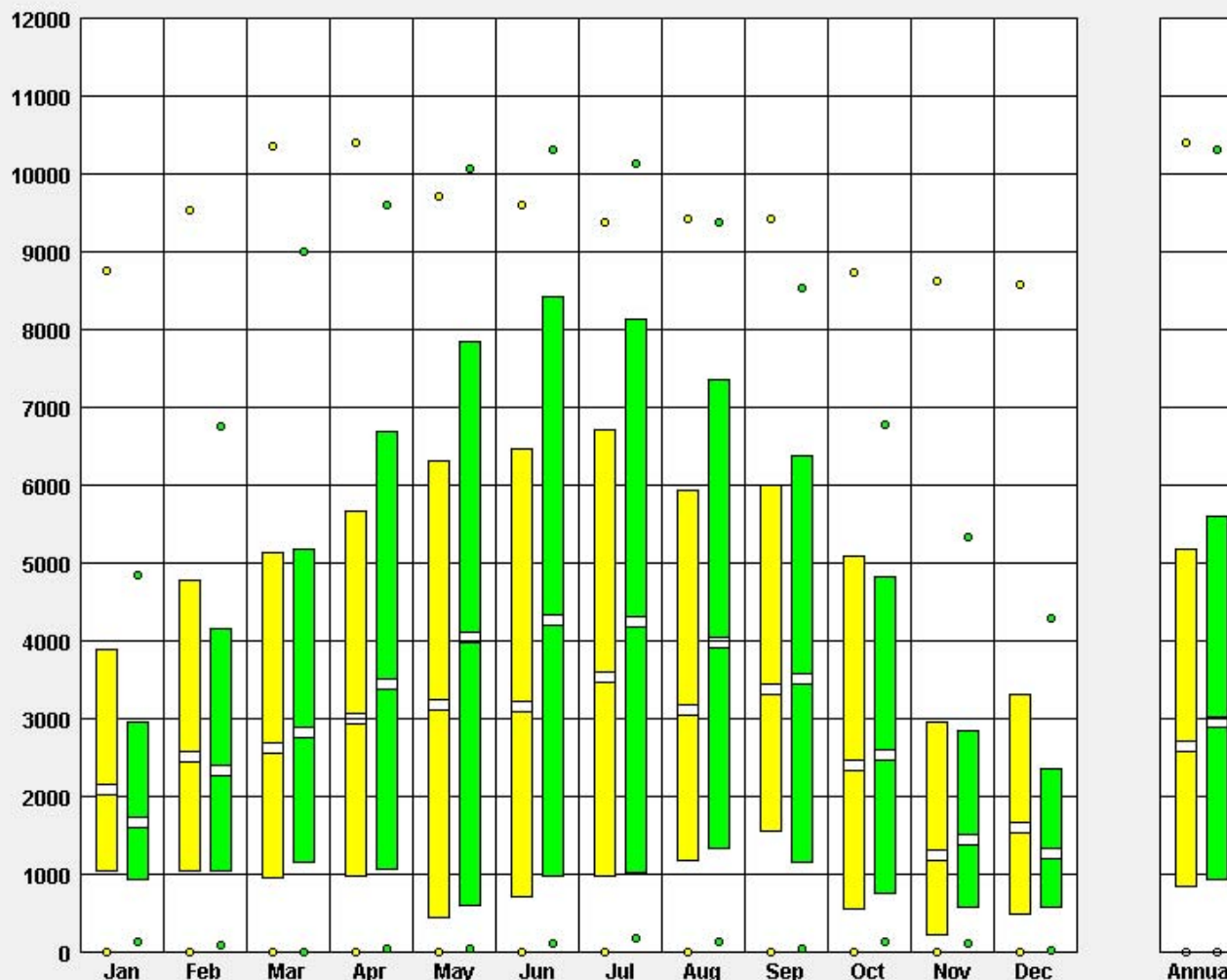

Building Orientation and Form

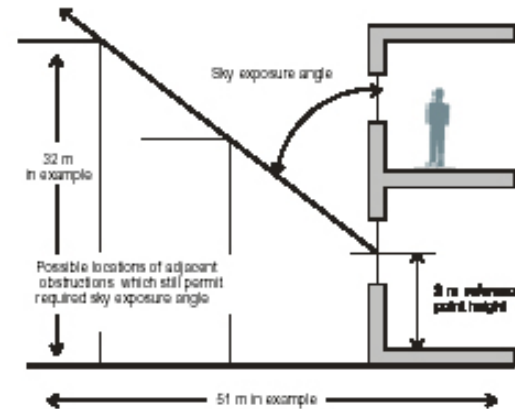

Using the Sky Angle to Determine Maximum Building Height

Sky Exposure Angle and Scale Ratio for Major Canadian Cities

Latitude	Major Cities	Required Sky Exposure Angle	Scale Ratio
42 - 46°	Halifax, NS Toronto, ON Montreal, Q	59°	1.69
46 - 50°	Vancouver, BC Winnipeg, MN St. John's, NF Shawinigan, QC	62°	1.86
50 - 54°	Edmonton, AB Prince George, BC Sept-Îles, QC	64°	2.08
> 54°	Churchill, MN Whitehorse, YK	66°	2.42

Consider the daylighting needs of surrounding areas. Use the required sky exposure angle to determine maximum building height that can be built, without shading nearby buildings.

$$\text{Maximum Building Height} = \frac{(\text{Distance Between Setback Lines})}{\text{Scale Ratio}} + 2$$

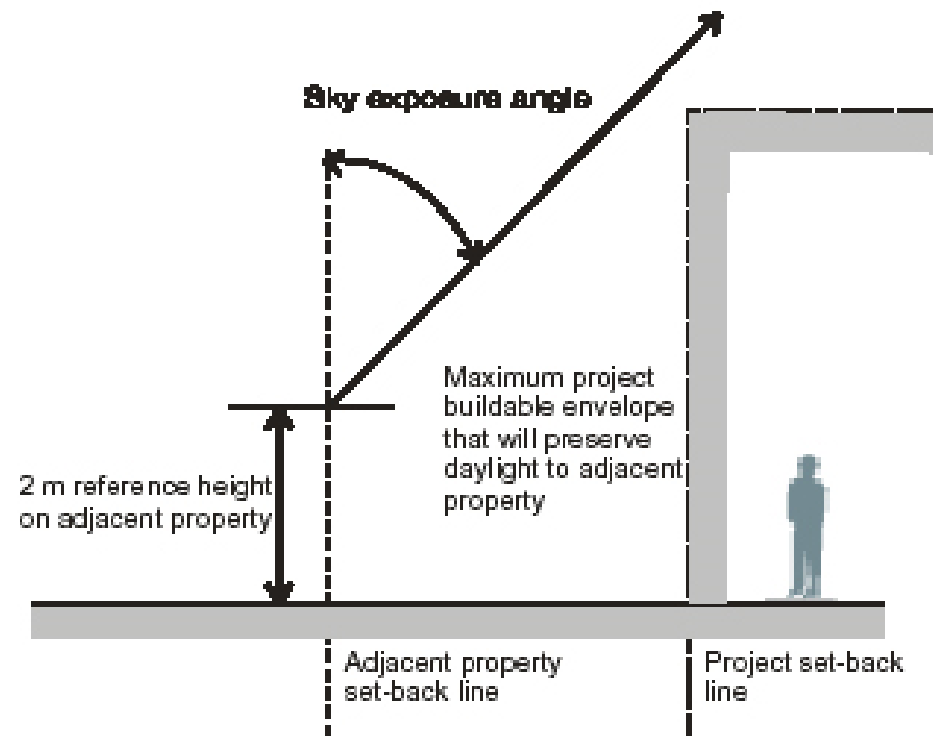

Using Scale Ratio to Determine Building Spacing

Building Orientation

Maximize southern exposure. The south facade allows the most daylight access and the best control of excess solar gain in the summer. This is the most desirable facade for daylighting and is best suited for rooms where variability in light levels is acceptable. Only marginal decreases in daylighting performance will occur for glazings facing 30° east or west of due south.

Optimize northern exposure. Although daylight exposure is less abundant on the north facade, the near-constant availability of diffuse skylight makes this the second most desirable orientation. For larger buildings where light uniformity and quality is key, large north-facing glazing areas can minimize electric light use.

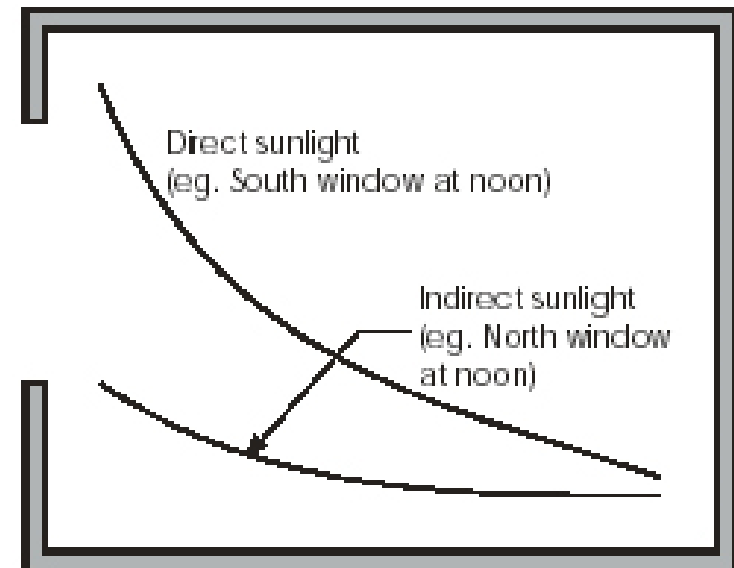

Light Distribution Throughout a Room

Building Form

Maximize perimeter exposure to daylight. Long and narrow footprints are better than square ones for access to daylight. Buildings can be arranged as a series of wings to minimize land requirements while still allowing access to daylight. The space between the wings should not be too narrow that they shade one another. Although square buildings have lower heating loads, daylighting the interior is difficult and the imbalance between perimeter heating loads and interior cooling loads necessitates a complex HVAC system. Multiple-storey buildings benefit the most from narrow plans that keep work areas within 10 metres of the exterior.

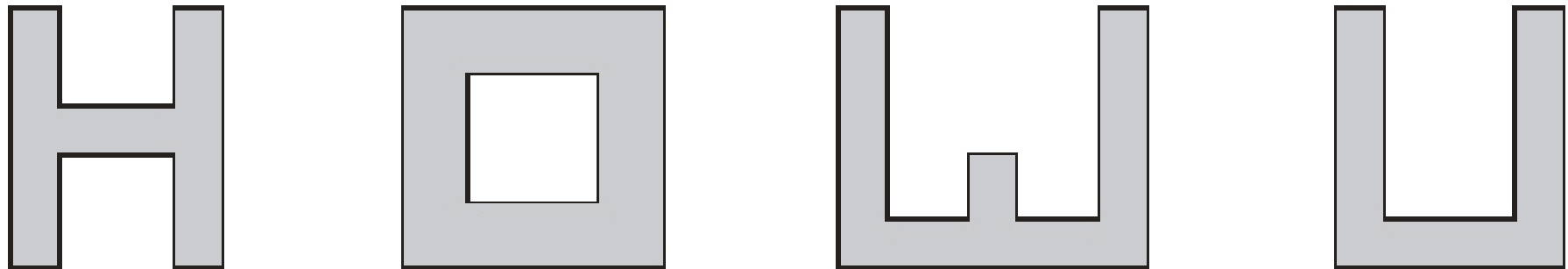

Examples of Building Footprints With High Daylight Access

Select room depth to correspond with daylighting zone. Room depths of 1.5 times the room's window head height will allow sunlight to provide adequate illumination levels and provide for balanced light distribution. For standard office ceiling heights of 3 metres, the amount of floor space that can be daylit is approximately 4.5 metres from the window. A building width of approximately 12 metres allows all offices to have access to daylight.

Avoid exposed west zones for work areas. Daylight on west-facing surfaces is generally hard to control, which leads to high cooling loads as well as occupant visual discomfort from glare. The west facade is best used as

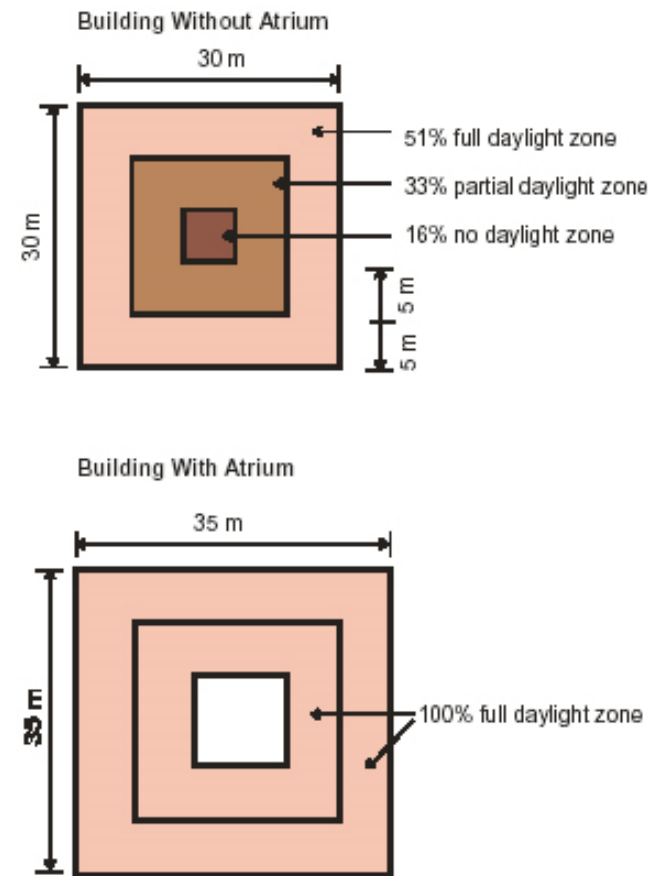

An atrium allows daylighting the core with only a modest increase in space requirements

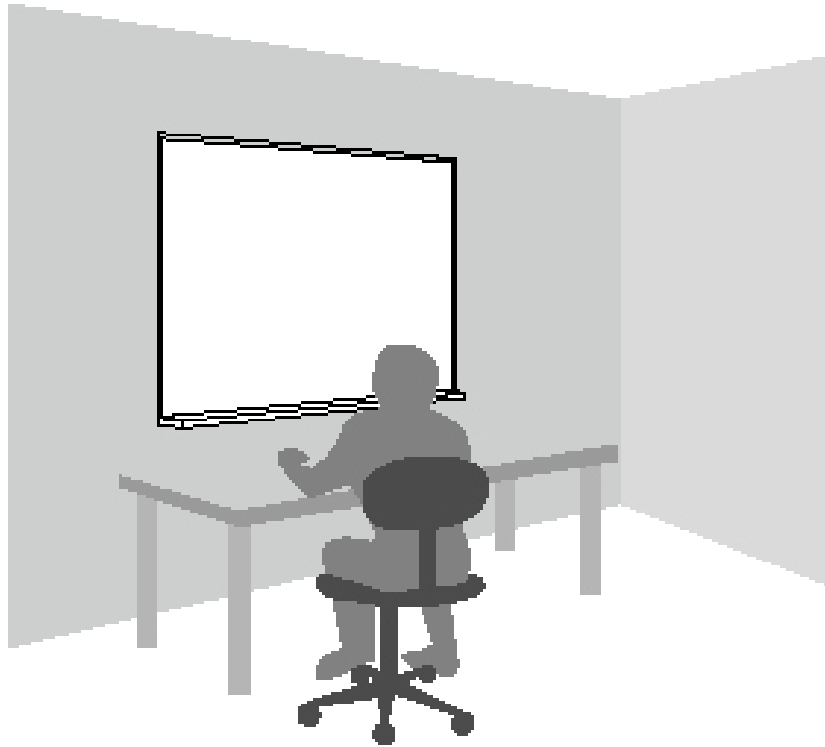

Facing the bright window creates a harsh contrast in comparison to your relatively dark task—this is very tiring for the eye to have both in the same field of view.

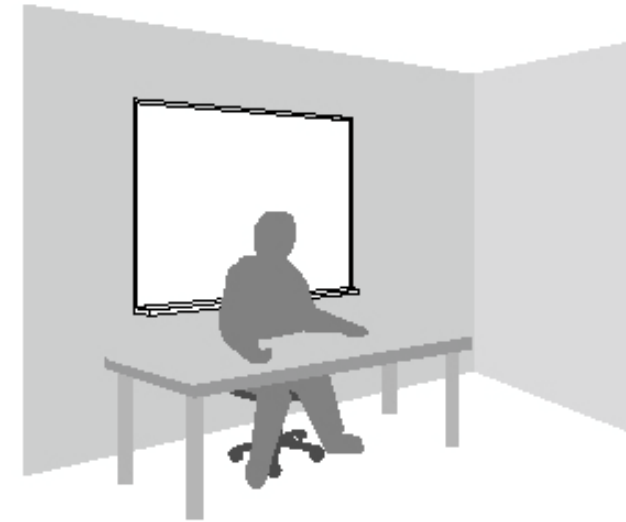

When the window is behind your back, you may shade your task and make it too dark to see easily. However, your computer screen may be difficult to see if it reflects light from the window.

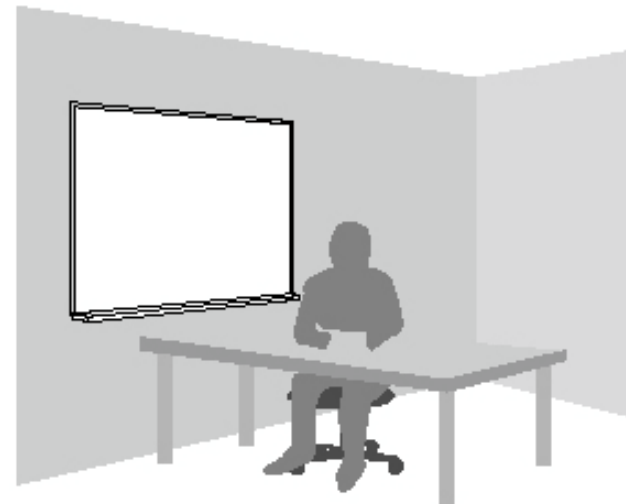

The most comfortable seating is with the window to the side—task is well illuminated and the source is not in direct line of sight.

Daylighting the Perimeter

Available daylight is a function of the amount of light that accesses exterior windows. It is a function of the angle as illustrated, calculated from the centre of the window.

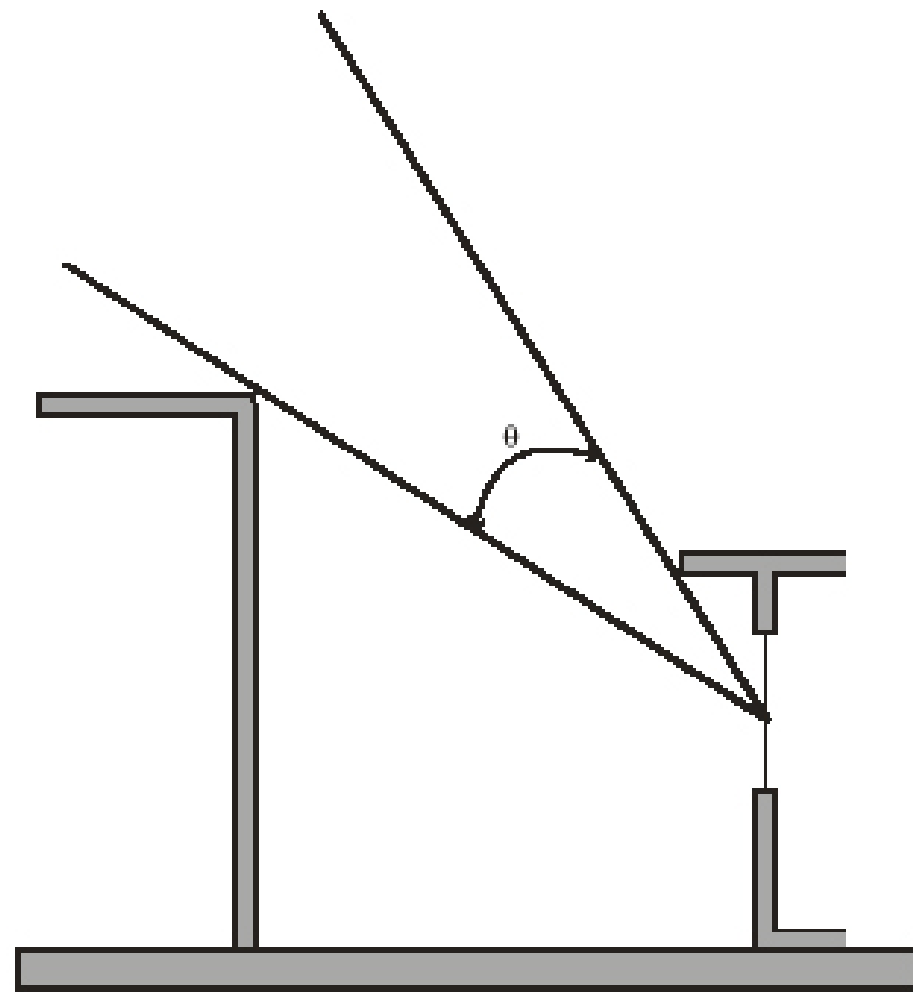

Sky Exposure Angle (θ)

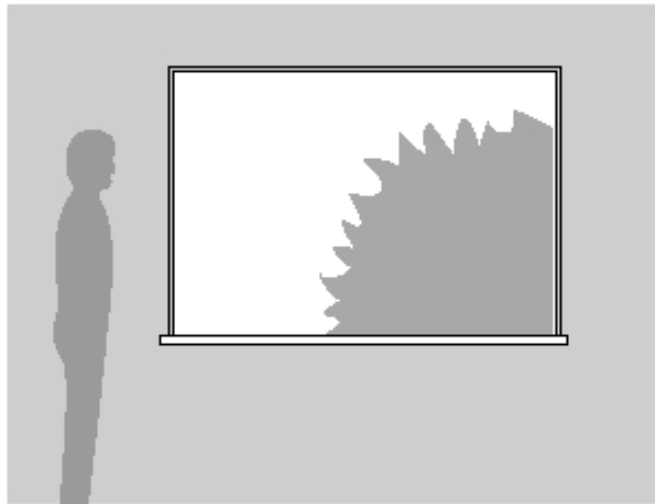

*< 50% obstructed
OF = 1*

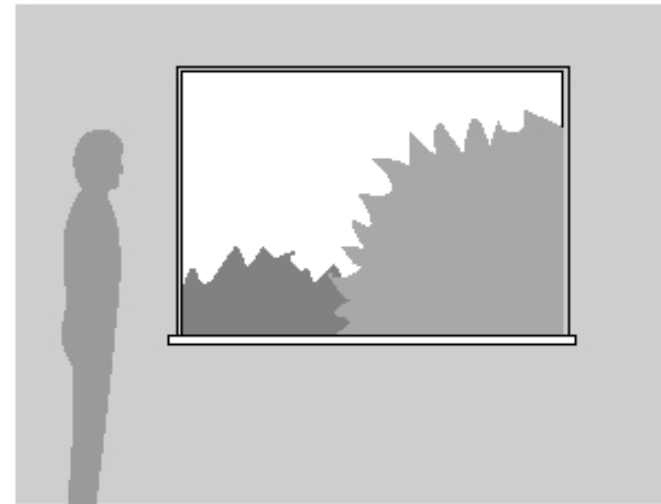

*≥ 50% obstructed
OF = 0.85*

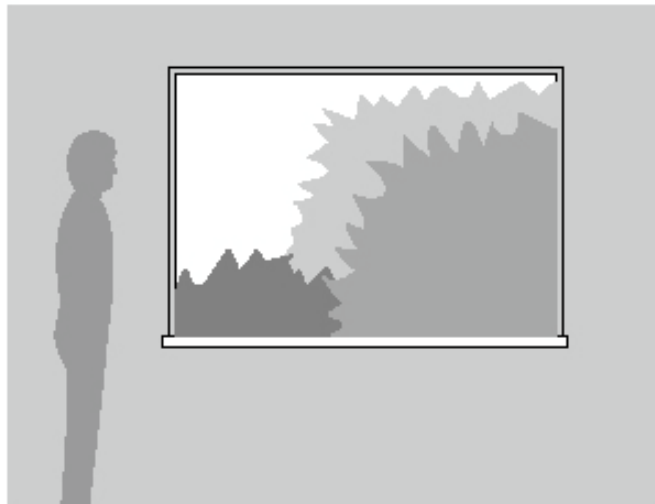

*≥ 70% obstructed
OF = 0.65*

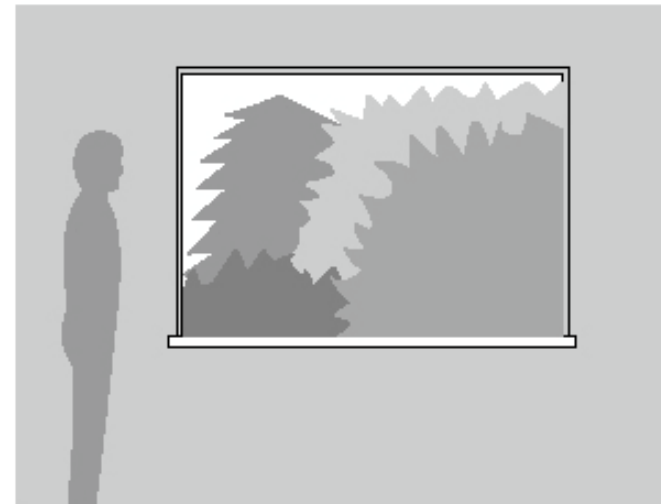

*≥ 90% obstructed
OF = 0.40*

Minimize contrast between the window and the wall by splaying or rounding the inside edges of the window. Windows will create less glare if the adjacent walls are not dark relative to the window. Splaying or rounding the edges will create a light transition that is more comfortable to the eye.

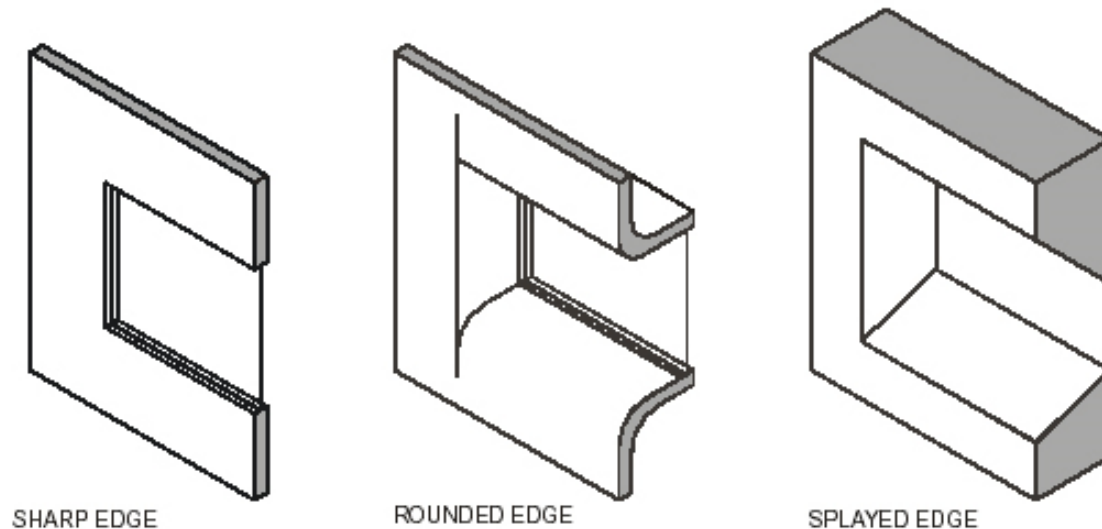

Inside Window Edges as Light Transitions

Separate the functions of window for daylight and for view.

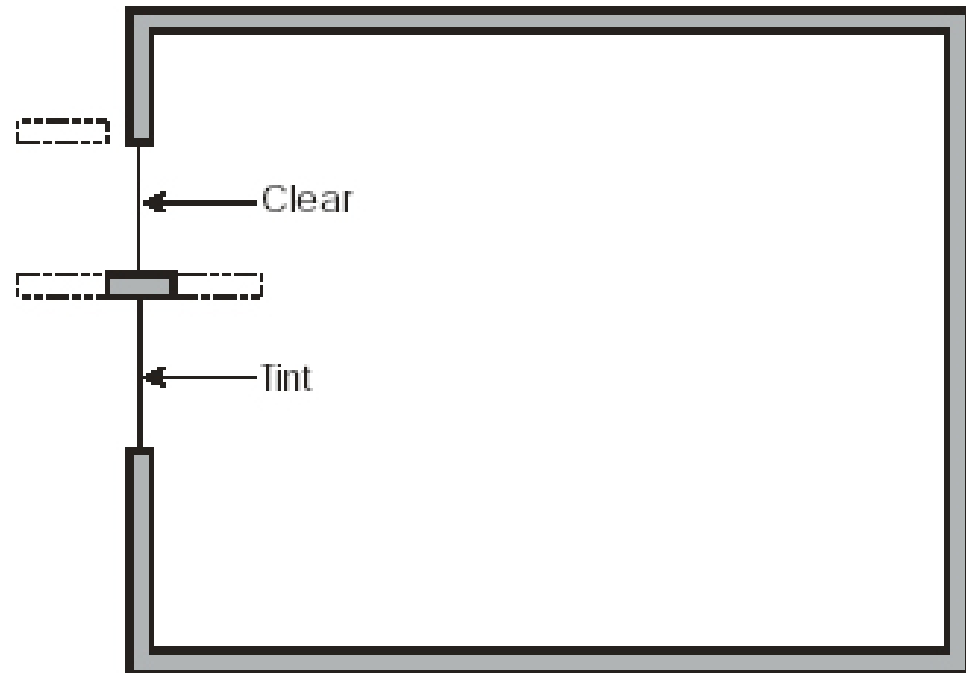

A Divided Window Provides for View
and Daylight

Higher windows and the use of light shelves with clerestories will give a larger depth of penetration for daylight.

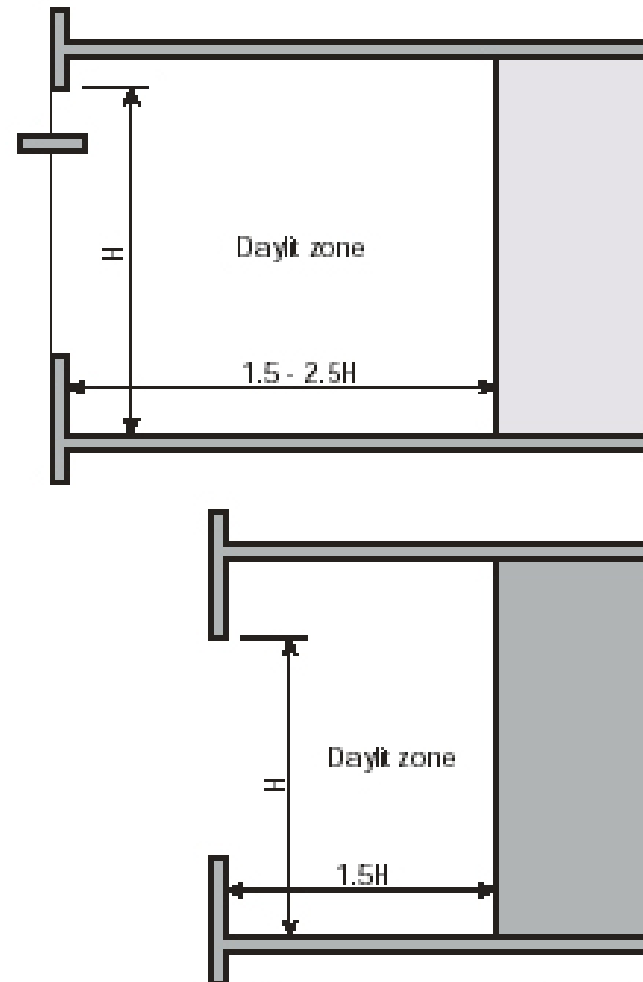

Daylight Depth as a Function of Window Height

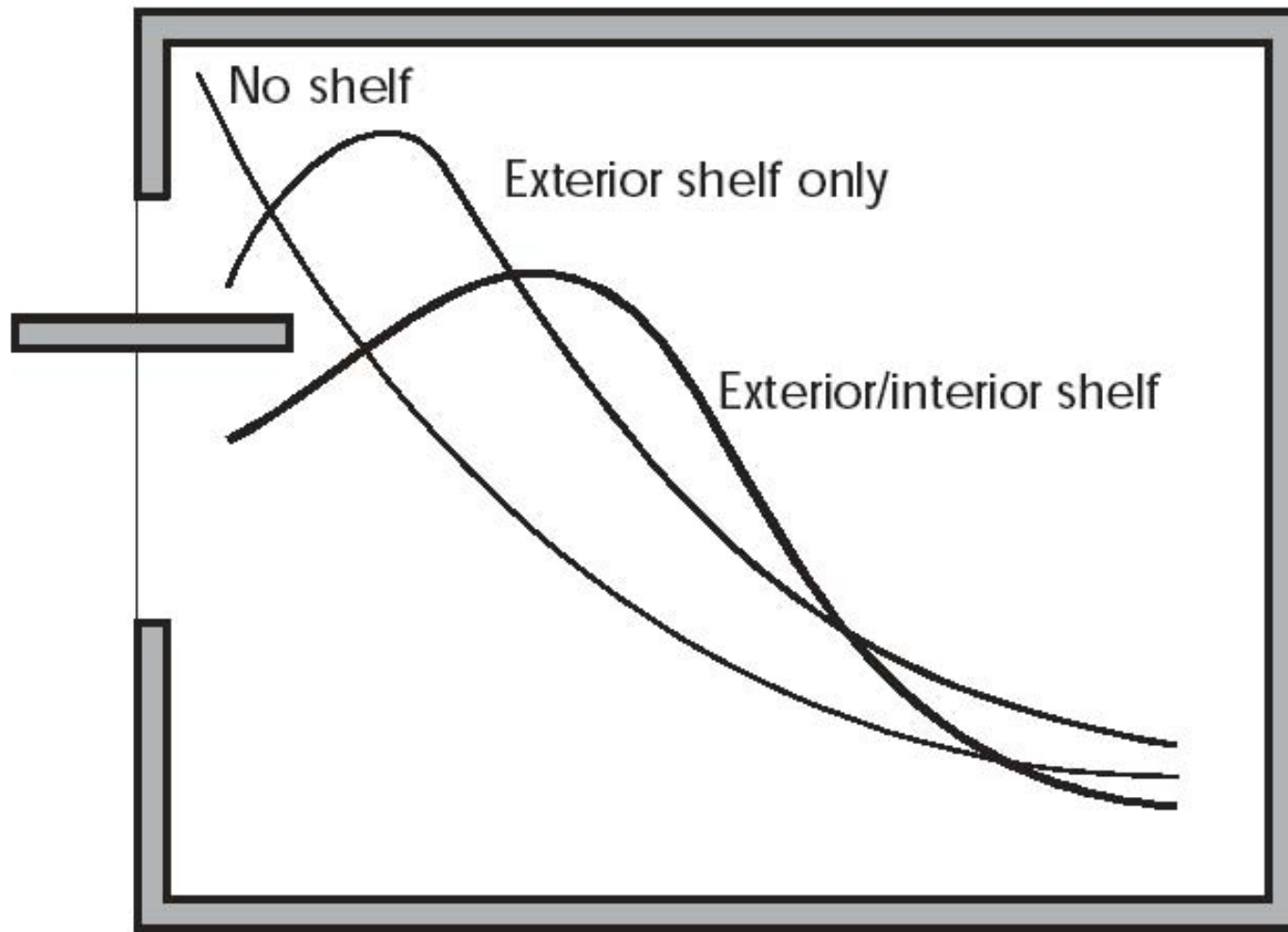

Light Distribution with Light Shelves

Exterior light shelves require special considerations for snow accumulation! NOT shown in this example.

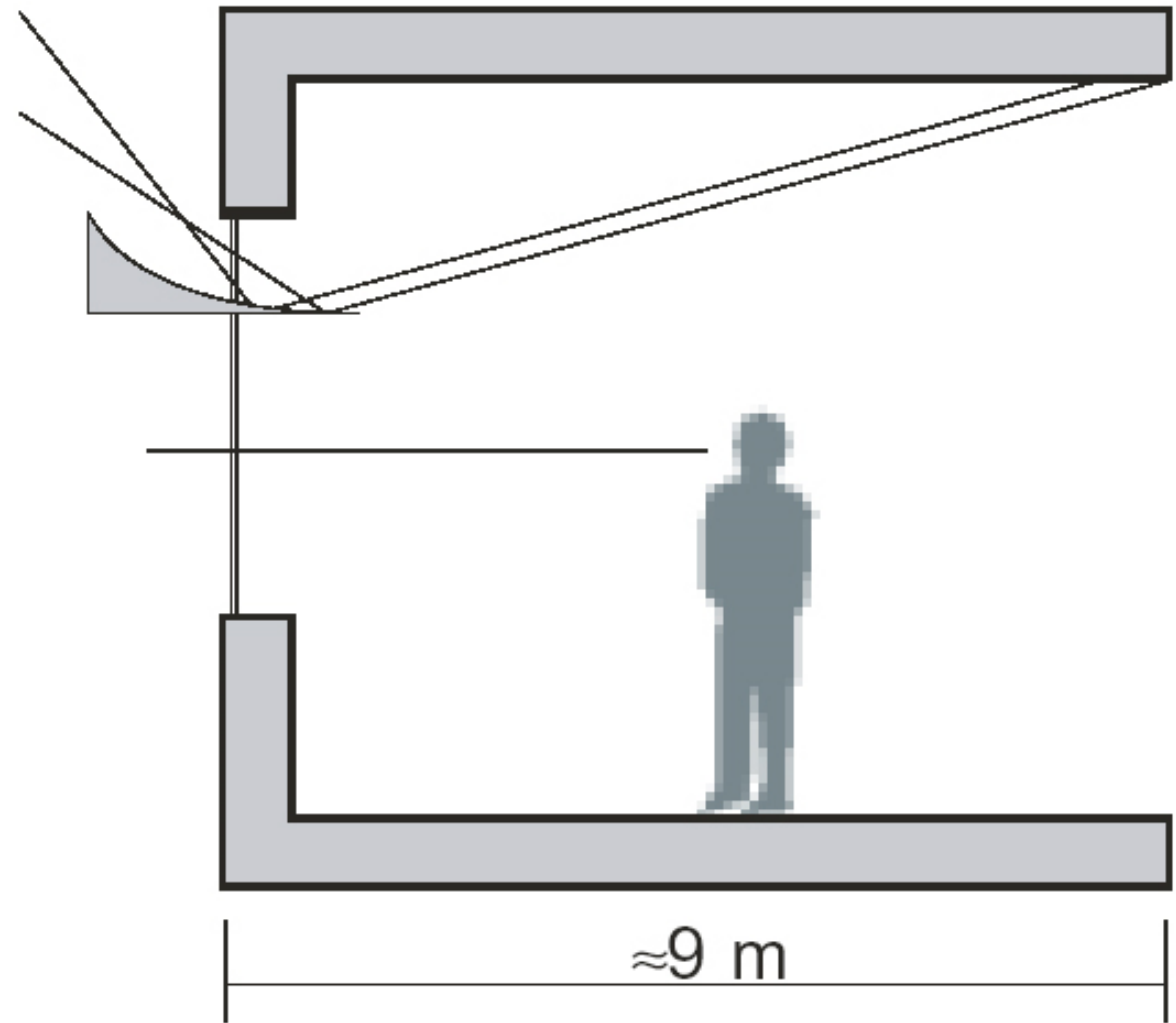

Interior and Exterior Light Shelves

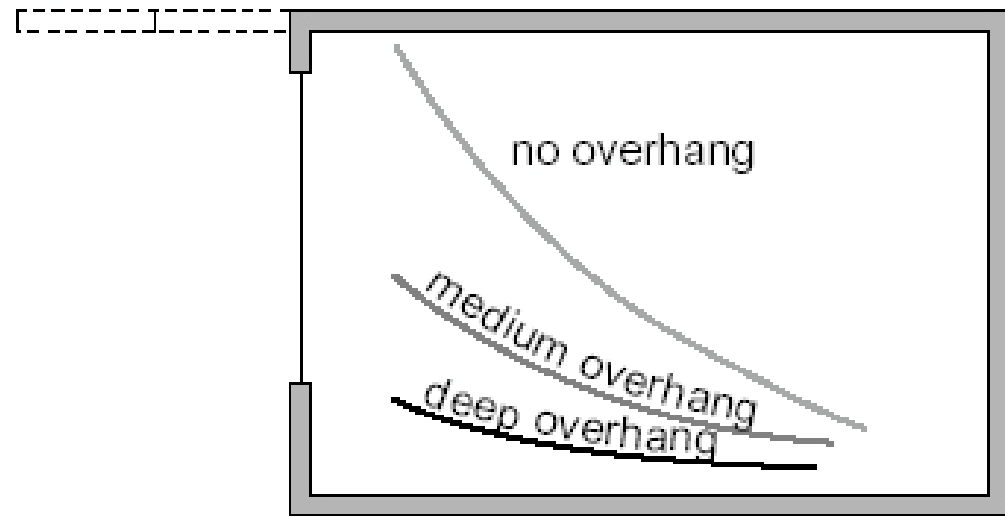

The curves indicate light levels. Overhangs reduce light and glare near the window, creating a softer gradient in the room.

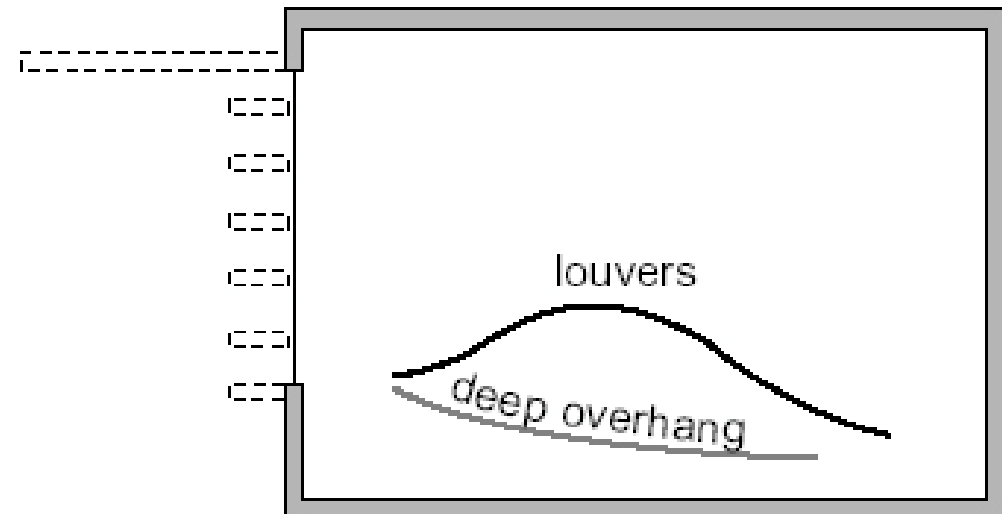

Break up the overhang for better distribution.

Window Sizing

The average daylight factor equation can be used to estimate the required window-to-wall ratio (*WWR*) for adequate daylighting.

$$WWR = \frac{A_{Glazing}}{A_{GrossWall}} \quad (\text{expressed as a fraction})$$

Where,

$A_{Glazing}$ is the net glazing area (window area minus mullions and framing, approximately 80% of the opening)

$A_{GrossWall}$ is the gross exterior wall area (width of the bay by floor-to-floor height)

Daylighting the Core

Skylights are an effective means of getting daylight deeper into the building plan, but are only useful on the top floor of the building...

There are several toplighting methods including skylights, monitors and clerestories. The following diagram illustrates the various toplighting possibilities. The sawtooth is a variation of a clerestory.

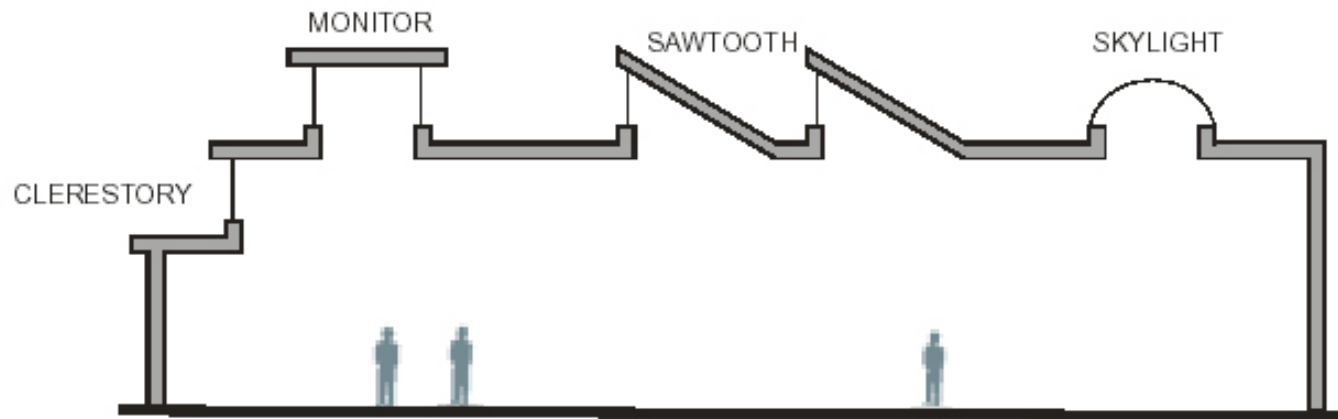

Example of Toplighting Strategies

Toplighting can produce more even illumination than simple side lighting.

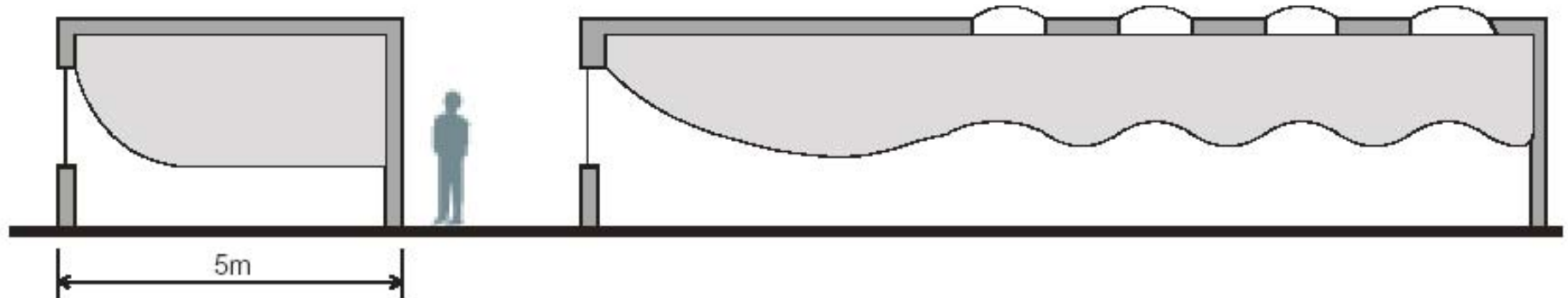

Improved Light Distribution in Long Spaces with Toplighting

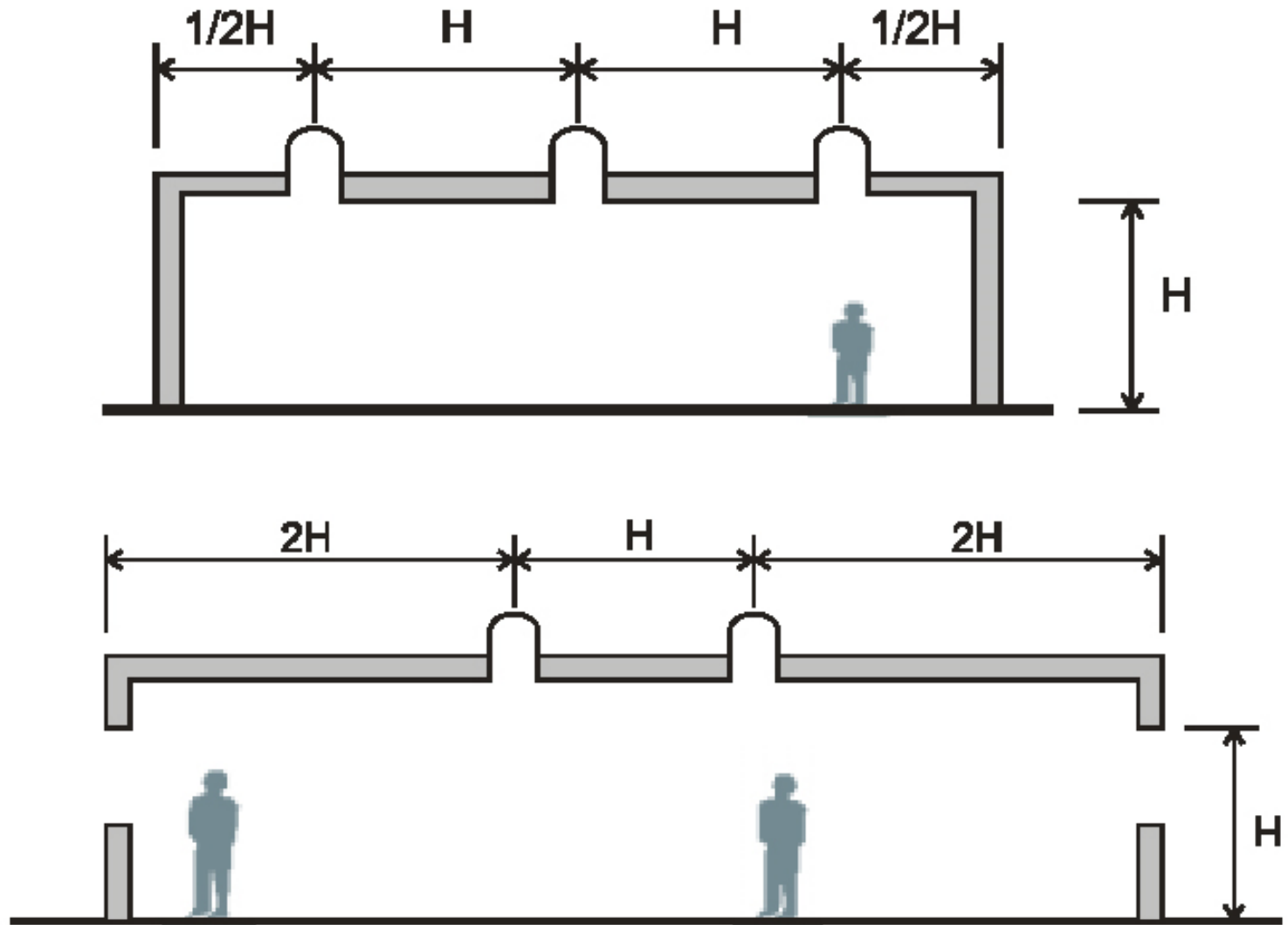

Skylight Placement as a Function of Building Height

Use sloped skylights. To improve light balances between winter and summer months, slope the skylight towards the north or south. A sloped skylight will collect more winter light and less summer light.

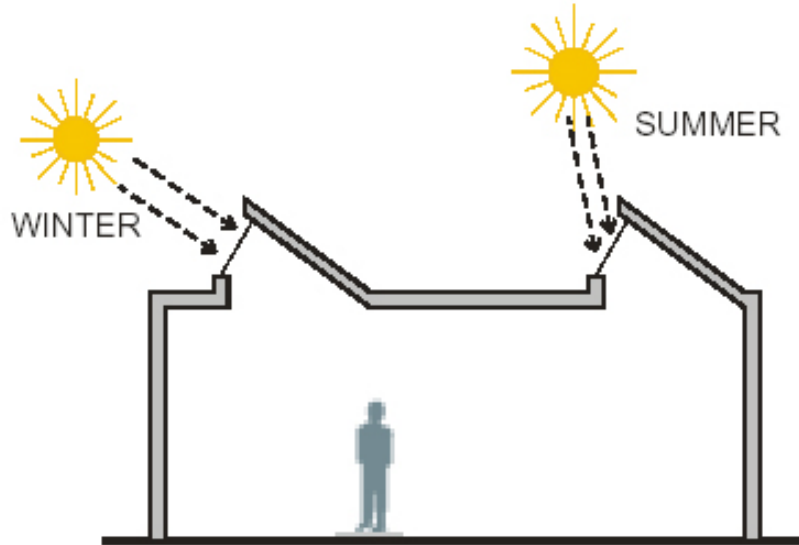

Sloped Skylight for Seasonal Light

Skylight Slope

South-facing: Skylight slope (from the horizontal) should be greater than the site latitude plus 23.5 degrees.

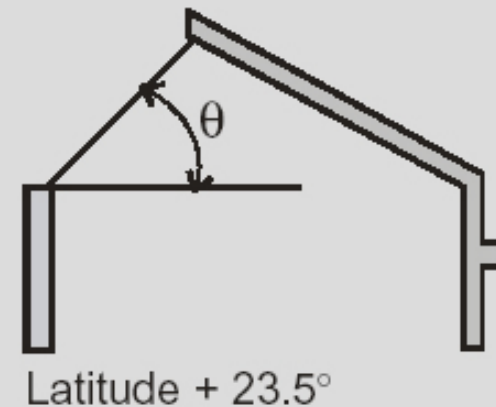

North-facing: Skylight sloped at latitude plus 23.5 degrees will receive the maximum daylight with a minimum amount of direct sunlight light entering the building.

Place skylights over the north wall. All walls, but especially the north wall, will act as a diffuse light reflector and will balance light entering windows from the south.

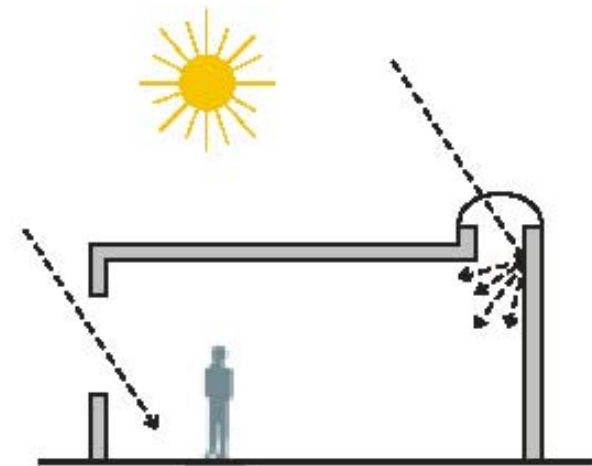

Light Diffusion after Entering Skylight

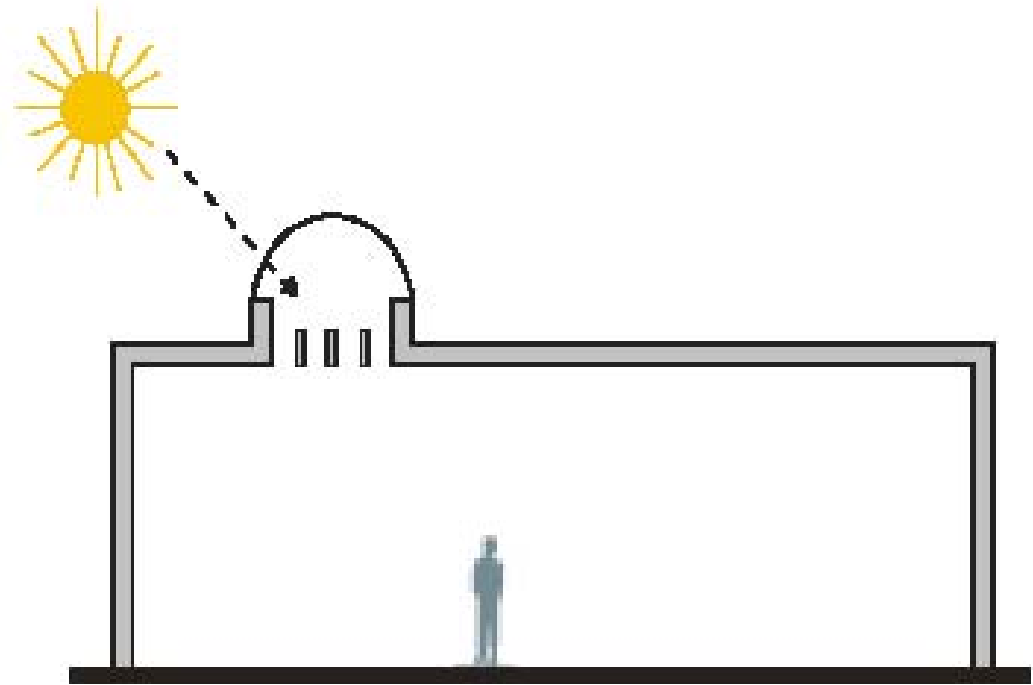

Diffuse Incoming Light for Glare
Reduction

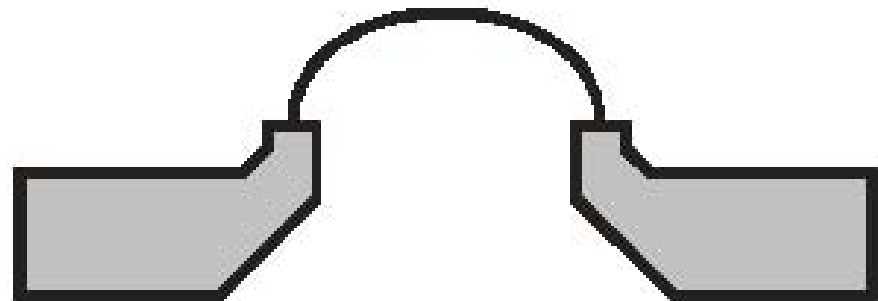

Splayed Opening on a Skylight



Kimbell Gallery: Louis Kahn
skylight detail

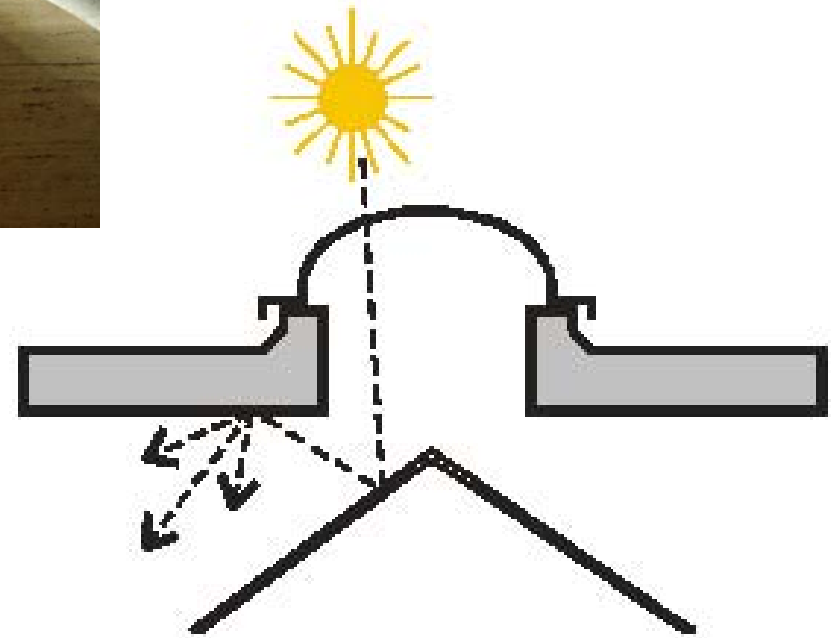

Interior Reflectors Diffuse Light

Space clerestories according to building height. The recommended spacing for clerestories and monitors is shown below.

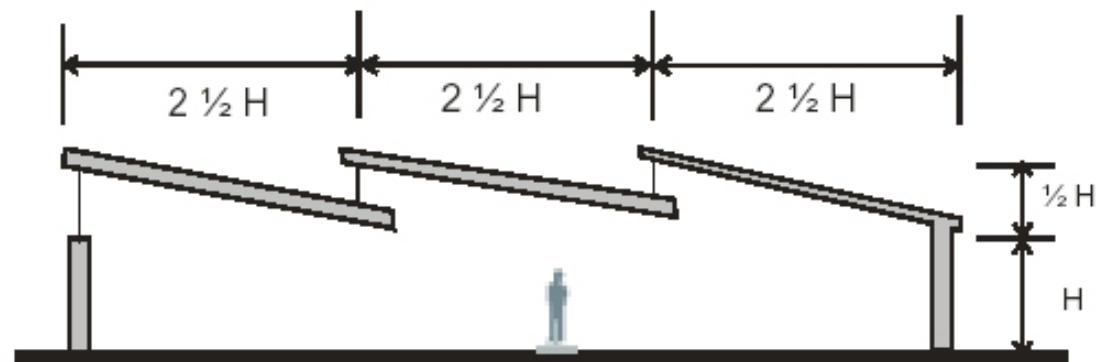
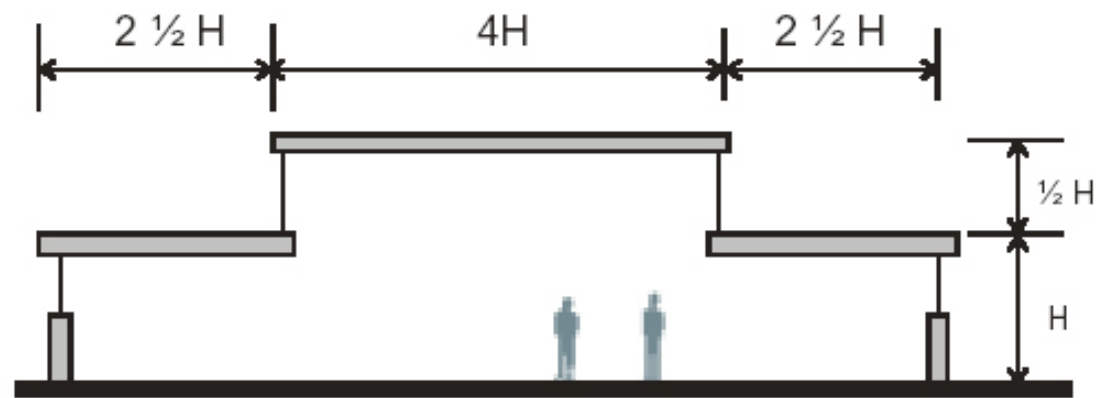

Clerestory Spacing as a Function of Building Height

Bounce light off interior wall. For south-facing openings especially, bouncing light off an interior wall will diffuse the entering sunlight.

Use overhangs and diffusing baffles. South-facing clerestories can deliver high illumination without glare when appropriately designed baffles are implemented. Design baffle spacing to avoid direct sunlight and direct field-of-view glare. The ceiling and baffles should have a matte, high-reflectance finish.

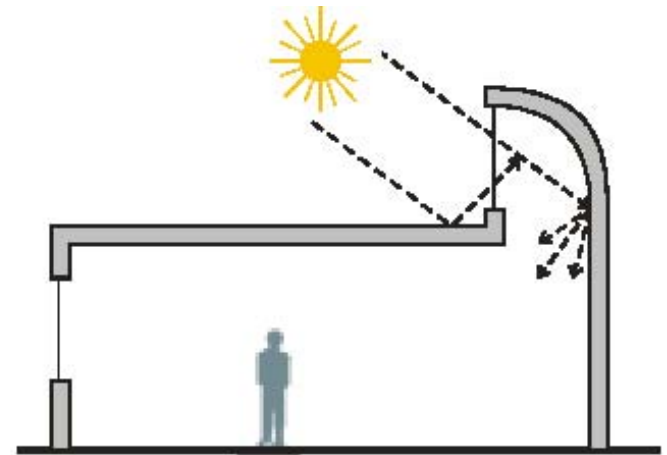

Diffuse Light with Interior Walls

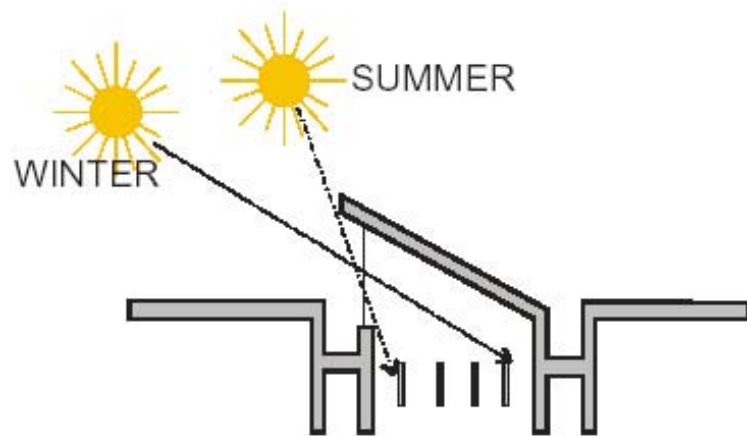

Minimize Clerestories Glare with Baffles and Overhangs

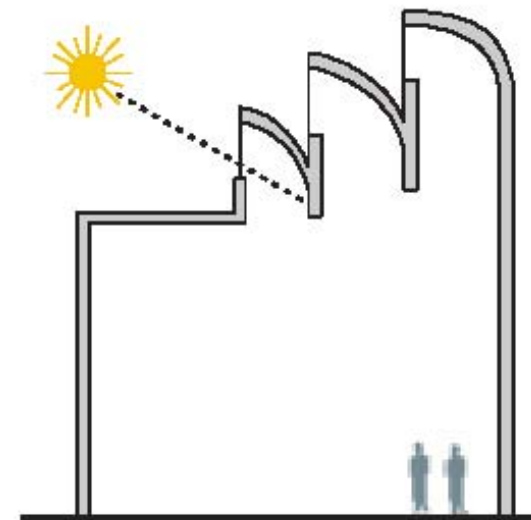

South-facing Clerestories with Light Scoops

Window and Glazing Selection

Visible transmittance (V_T) A measure of the fraction of visible light that passes through a glazing.

Visible reflectance The fraction of visible light that is reflected off the glazing. It is usually measured for both the inside (the interior mirror effect at night) and the outside (exterior view) of a glazing.

Solar Heat Gain Coefficient (*SHGC*) This parameter is a ratio of total transmitted solar heat to incident solar energy for a glazing. The ratio ranges between 0 and 1 and is an indication of the total heat transfer of the sun's radiation. An older, similar term, the Shading Coefficient (*SC*), is the ratio of the solar heat gain of a glazing to that of a clear single glazing.
 $SC \approx 1.15 \times SHGC$.

U-value A measure of heat transfer through a glazing per degree temperature difference across the window expressed in $W/(m^2K)$.

Ultra-violet transmittance The percentage of ultraviolet radiation that passes through a glazing.

Spectral selectivity The ability of a glazing material to respond to different wavelengths of solar energy. Ideally the glazing will admit visible light, but reject unwanted invisible infrared heat.

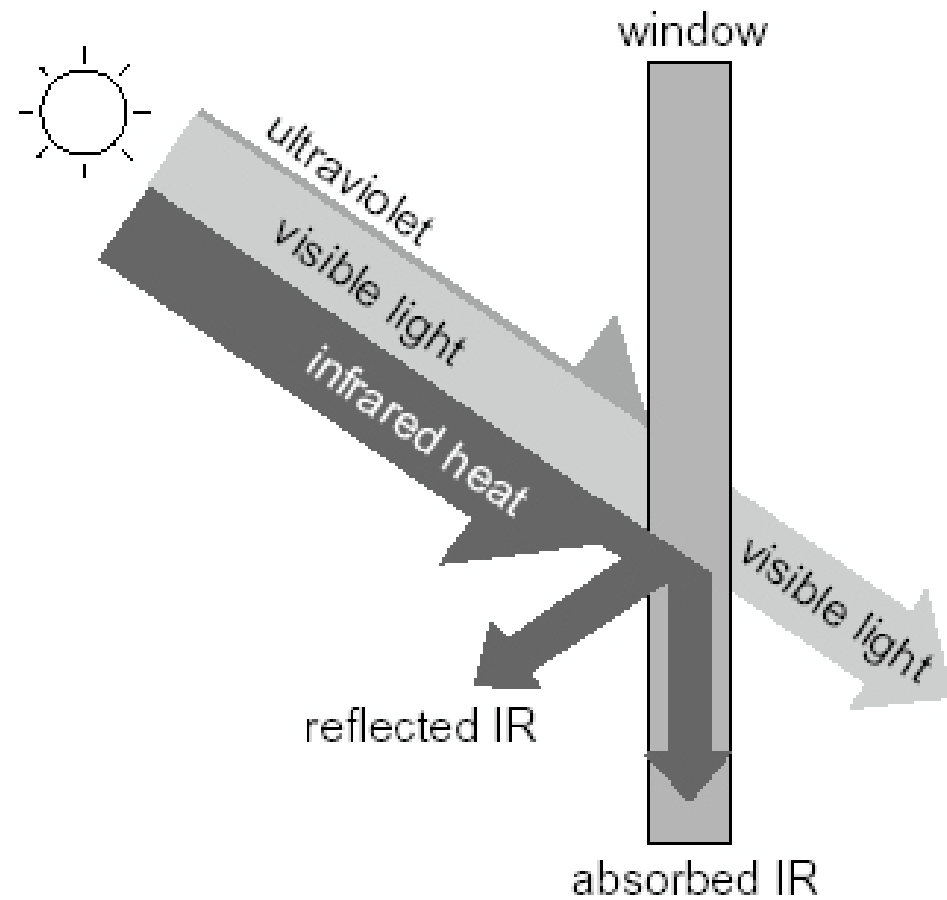

An ideal spectrally selective glazing admits only the part of the sun's energy that is useful for daylighting.

Typical U-values for Glazing and Window Systems

Glazing System	Center-of Glass U-value (W/(m ² K))	Total Window U-value (W/(m ² K))	
		Typical Frame	High-Performance Frame
Single	5.91	6.30	5.90
Double	2.73	3.51	3.03
Double, hard low-e + argon	1.70	2.63	2.19
Double, soft low-e + argon	1.42	2.39	1.94
Triple	1.76	2.63	2.22
Triple, hard low-e + argon	1.25	2.19	1.79
Triple, soft low-e + argon	0.80	1.79	1.40

[Source: 1997, ASHRAE Fundamentals Handbook (SI), Table 5, p 29.8.]

Typical Light Transmission and SHGC for Glazing Systems

Glazing Light Transmission/Solar Heat Gain Coefficient (in percent)					
Glazing System (6mm glass)	Clear	Blue/Green	Spectrally Selective	Grey	Reflective
Single	89/81	75/62	71/51	43/56	20/29
Double	78/70	67/50	59/39	40/44	18/21
Double, hard low-e + argon	73/65	62/45	55/34	37/39	17/20
Double, soft low-e, + argon	70/37	59/29	53/27	35/24	16/15
Triple	70/61	59/42	53/34	34/40	17/19
Triple, hard low-e + argon	64/56	55/38	52/31	32/36	15/17
Triple, soft low-e, + argon	55/31	52/29	50/27	30/26	14/13

[Source: 1997, ASHRAE Fundamentals, Table 11, p. 29.25]

Maximum Recommended Window U-values

Region	Principal Heating Source			
	Electricity, Other	Oil	Propane	Natural Gas
	Maximum U-value, W/(m ² °C)			
Newfoundland	1.80	3.20	3.20	-
PEI	1.80	2.10	2.10	-
Nova Scotia	1.80	3.20	2.10	-
New Brunswick	2.10	3.20	1.80	-
Quebec, Southern	2.10	2.10	2.10	2.10
Ontario, Southern	2.10	3.20	3.20	3.20
Manitoba, Southern	2.10	2.10	2.10	2.10
Saskatchewan	1.80	1.80	1.80	3.20
Alberta, Southern	2.10	2.10	2.10	3.20
British Columbia, Southern	3.20	3.20	3.20	3.20
Northern Canada	1.20	1.80	1.80	-

Note: Data is for WWR of up to 0.4

Use multiple layers of glazing. The insulative effect of the air trapped between panes of glass can significantly reduce heat conduction through the window. To achieve U-values below $1.5 \text{ W}/(\text{m}^2\text{K})$ requires triple-glazed windows.

Consider the use of film technologies. Using two films with a double glazed window will provide the thermal performance of a quadruple-glazed assembly at considerably less weight.

Use inert gas fills. The most common fill gases are argon and krypton. Argon is more commonly used despite the fact that krypton has better heat retaining properties. Krypton is approximately 200 times more expensive per unit volume than argon, although, since it works well in small pane spacings, it is used in situations where a reduction in the overall thickness of a multi-pane assembly is desired. The cost of inert gas window fills is about \$3 to \$5/m² of window.

Use low-e coatings for most applications. Applying a low-emittance metallic oxide film to a glazing will help to minimize radiant heat transfer. Low-e coatings are a mature and cost-effective technology. Most low-e coatings have high visible transmission so they will not reduce daylight availability. Some types of low-e coatings reflect solar gains while others transmit the solar gains.

Types of Low-e Coatings

There are two types of low-e coatings: soft and hard. Both coatings have low emissivity values for reduced radiative heat loss, are durable (if in a sealed glass unit) and are clear to the human eye. They do have slightly different heat transfer properties so that each coating has advantages over the other depending on the application.

Soft or Sputtered Low-e Coatings: These coatings are sprayed onto glass to achieve a low emissivity. They are referred to as “soft” because they are susceptible to degradation if exposed to the atmosphere. Provided they are in a sealed glass unit, they will retain their properties. Early soft coats had an emissivity of 0.1. More recently developed coatings achieve emissivities of less than 0.05. Most of these coatings are spectrally selective, in that they have high visible light transmission but low solar transmission. These coatings are best suited to medium-to-large commercial buildings or buildings with high air conditioning loads. Product trade names include Cardinal Low-e squared, AFG Ti-R, AFG Ti-AC, PPG Solarban 60, and Guardian Low-e Performance Plus II.

Hard or Pyrolytic Low-e Coatings: These coatings are applied during the manufacture of the glass. They are extremely durable even when not in a sealed glass unit. The emissivity is slightly higher than soft coats at 0.15 to 0.20. Most hard coatings have high visible and solar transmission. These coatings are best suited to residential and small commercial buildings or locations where air conditioning is rarely used. Product trade names include Pilkington Energy Advantage, AFG Comfort E2 and PPG Sungate 500.

Use low U-V transmission glazings where space contents are valuable. Since U-V can damage fabrics and paintings, a low U-V transmission glazing should be considered where such exposure is undesirable, such as in museums.

Use blue/green or spectrally-selective glazings over grey and reflective glazings. Spectrally-selective glazings are specially designed for high visible light transmission and low solar heat gain coefficient.

Avoid reflective glass. Reflective glass is coated with thin layers of metal (e.g. copper, silver, gold) or with semiconductors that reflect the solar heat gain and light. Because of their high daylight reflection, reflective glass is not compatible with daylighting design.

Locate low-e coating to achieve desired SHGC. A successful coating is also dependent on its location within the glazing assembly. By convention, glazing surfaces and layers are numbered from the outside in. If solar heat gain is to be increased (e.g. in residential or small commercial applications), then a coating on Surface 3 will be more effective than on Surface 2. For medium and large commercial buildings, the low-e coating is better on Surface 2. The U-value and inside center-glass temperature is not dependent on location.

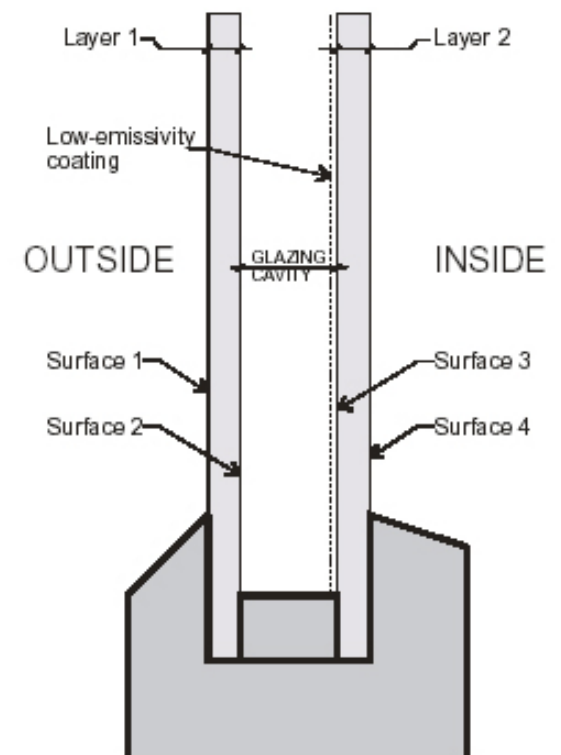

Typical Double-Glazed Window Assembly

Energy Saving Driven Strategies

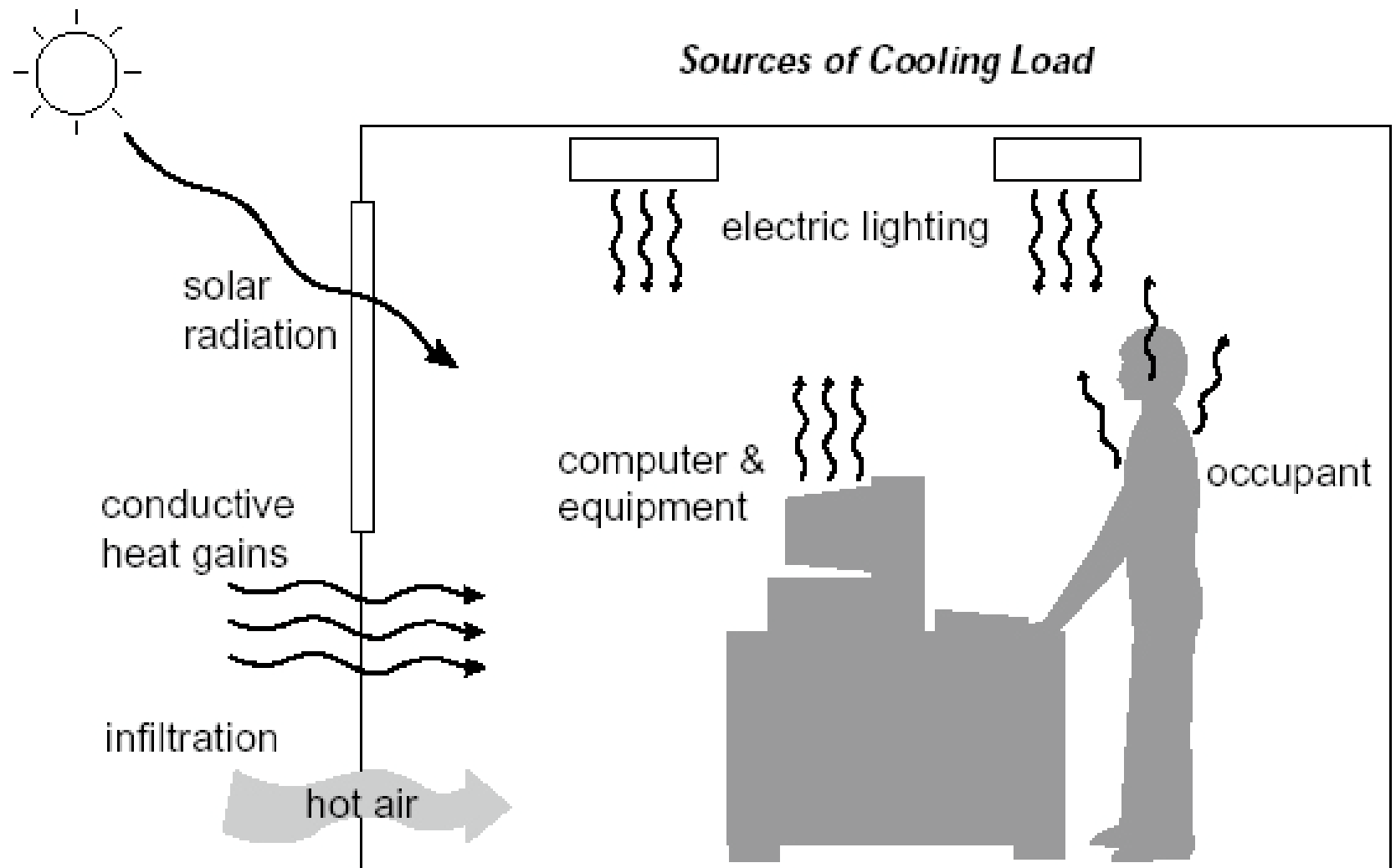

Different types of light fixtures have different light distribution. The type of fixture used in combination with daylight must be carefully chosen for its most appropriate characteristics -- as well as to make sure that the light is reaching the most suitable surface.

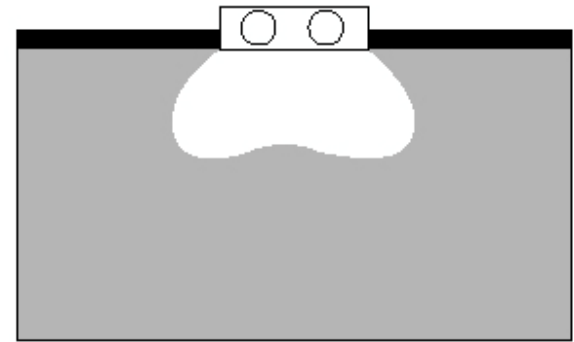

Direct lighting, typical candlepower distribution from ceiling-mounted luminaire

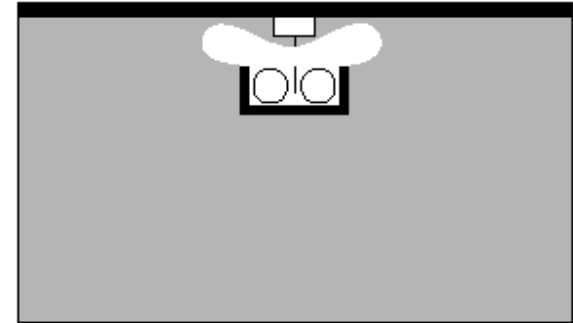

Indirect lighting, typical candlepower distribution from suspended luminaire

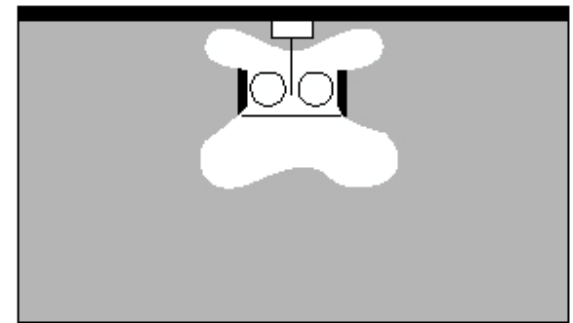

Direct/Indirect lighting, typical candlepower distribution from suspended luminaire

Controls can be used that adjust the lights to come on and off based on the illumination levels in specific zones of (deep) rooms, rather than having everything on or off. These controls can also be specified to be dimmable as well, for more even lighting.

Schematic representation of lighting in a room with stepped lighting controls. The curves show relative light levels from both daylight and electric light. As the daylight level falls off with distance from the window, the electric lighting makes up the difference so that total illumination is evenly maintained at design levels throughout the room.

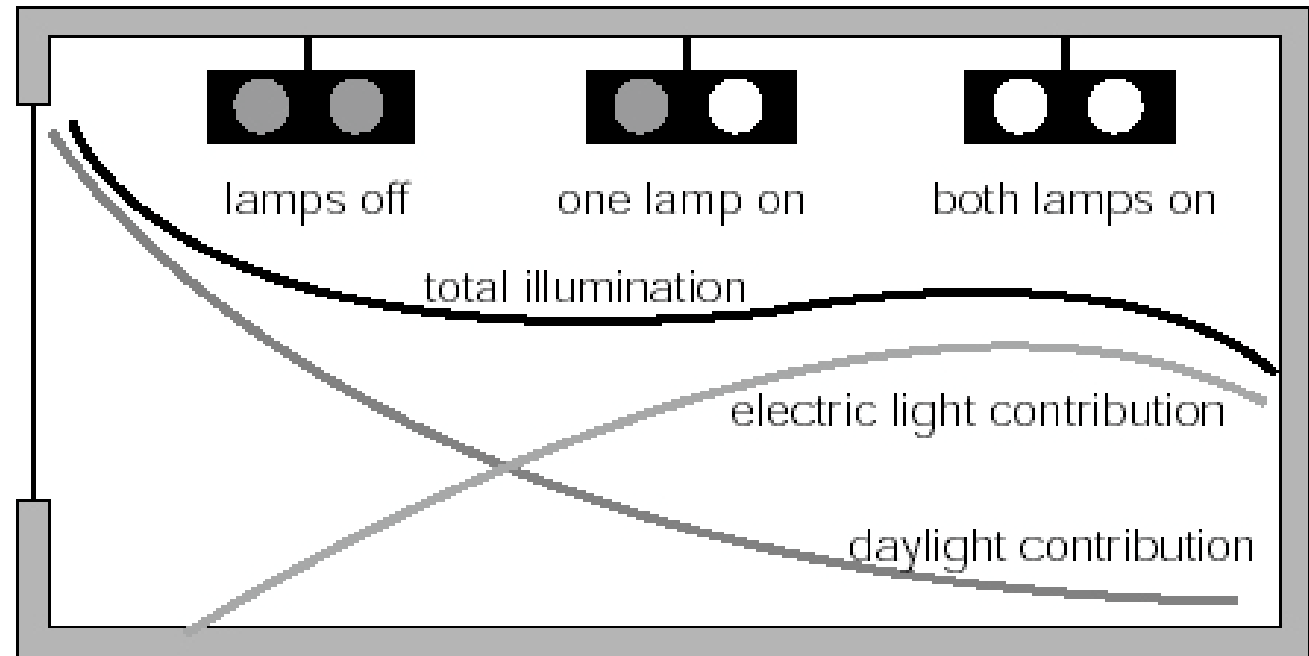

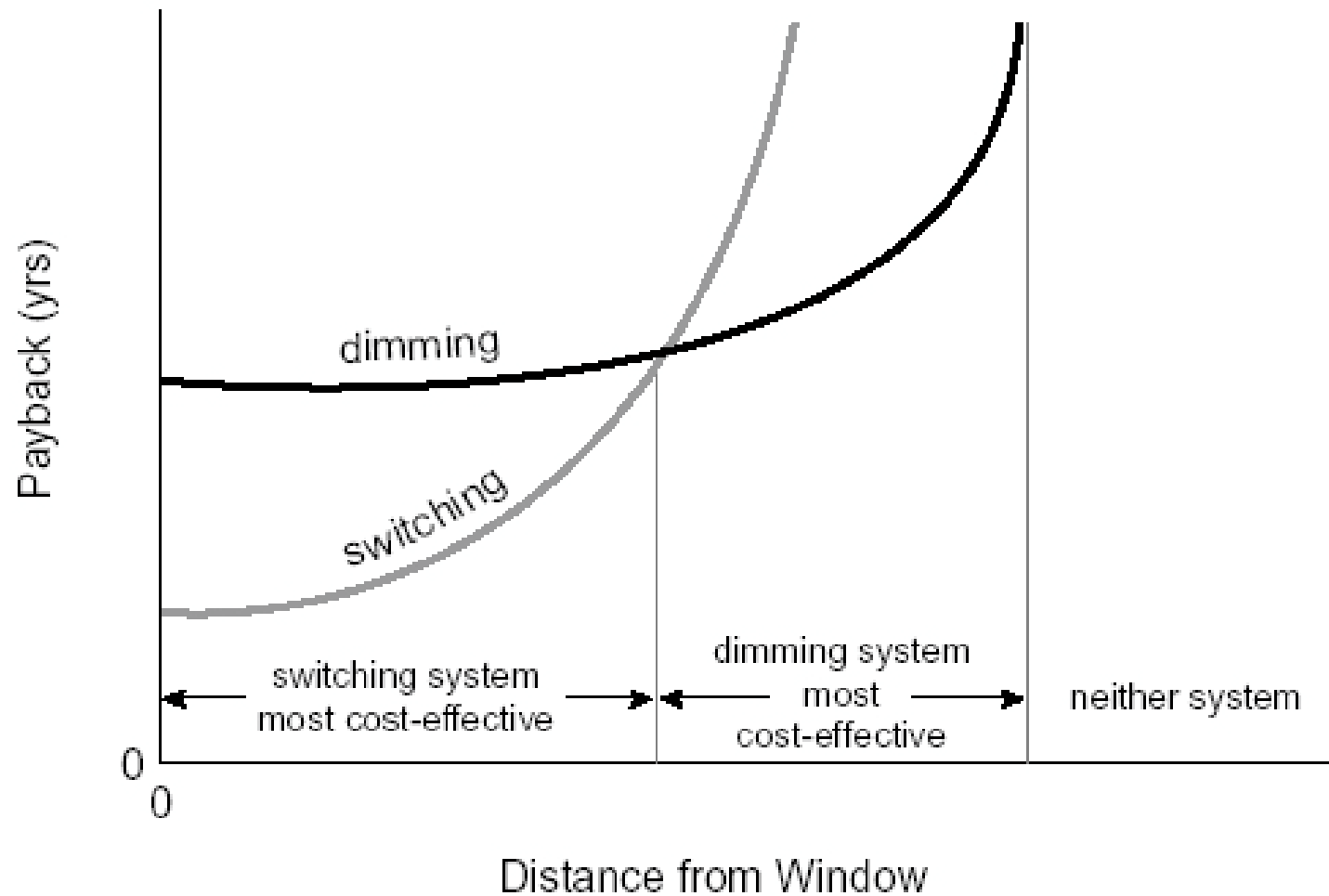

Dimming/Switching payback chart

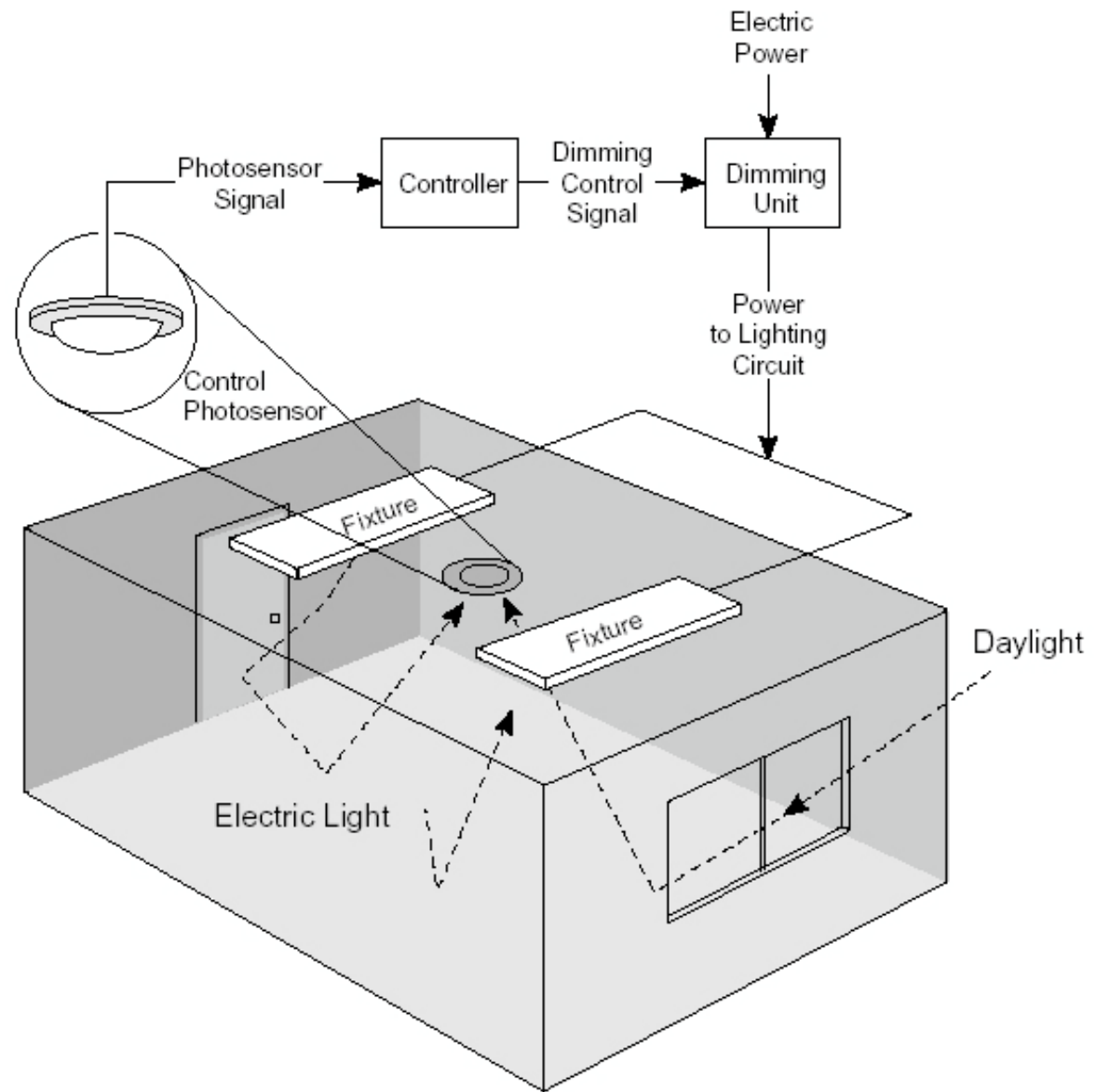

Schematic diagram of a room with a photoelectric dimming system. The ceiling-mounted photosensor reads both electric light and daylight in the space, and adjusts the electric lighting as required to maintain the design level of total lighting.

Galleries: A Special Problem

UV can under no
circumstance hit artwork. If it
does, the gallery is a failure!

Menil Gallery:
Houston, Texas
Renzo Piano Architect

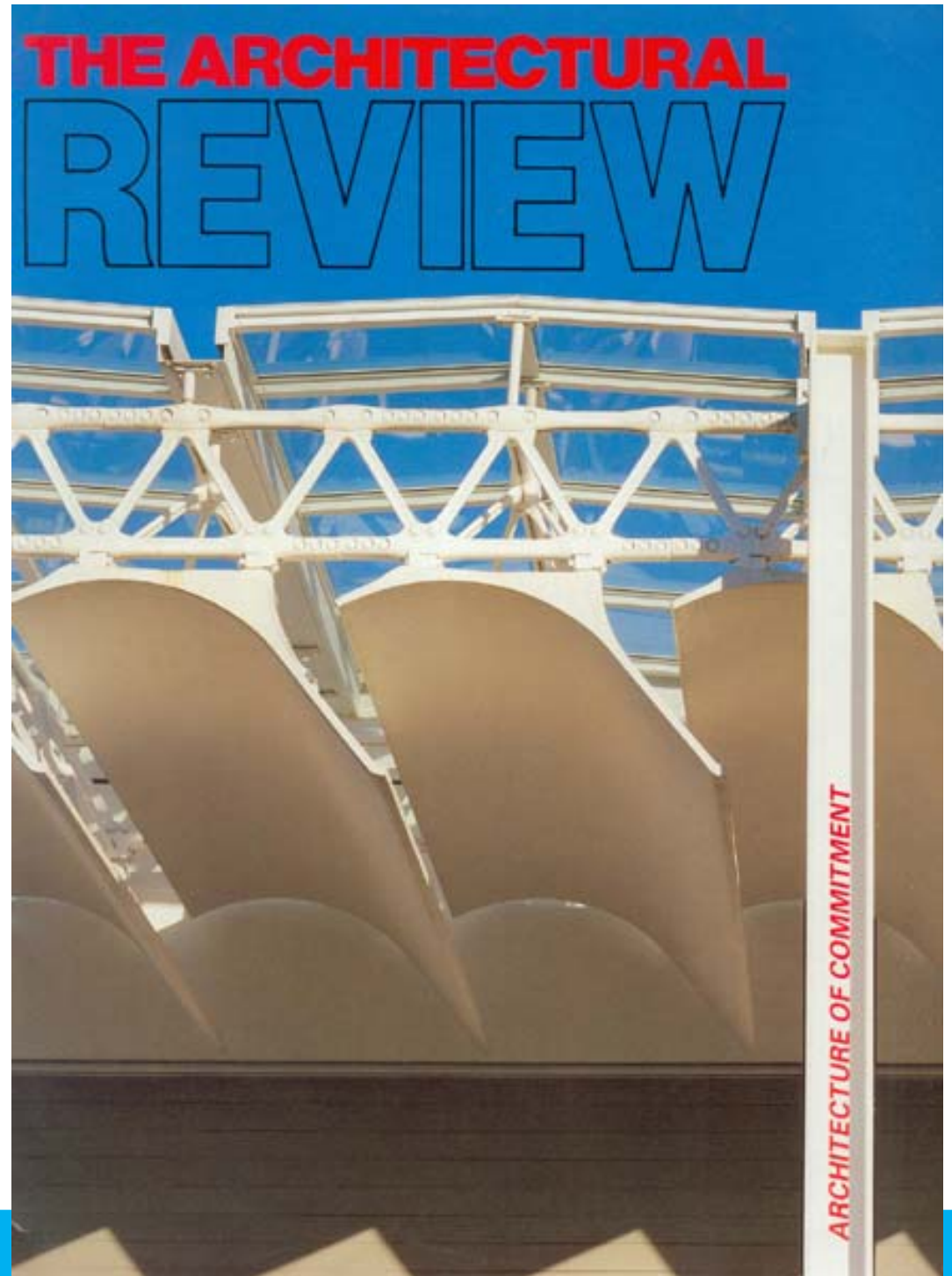



Arch 226: Environmental Building Design



3, it's not everyone, for example, who could bring themselves to do a museum in weatherboard, scaled just slightly over the surrounding domestic norm, and coloured the same off-ethnic subfusc as its neighbours. (The similarities, though,

are skin deep, since the weatherboarding sits on steel framing, not timber; the boards are not cedar but, on the Menil Foundation's insistence, valuable heart cypress milled from South Carolinian trees up to 2000 years old;

and the colour is not paint, as but a pigmented weather-stain designed to accelerate the natural ageing and silvering process of timber.)
4, the museum's main entrance, Sul Ross Street.



Arch 226: Environmental Building Design



Arch 226: Environmental Building Design

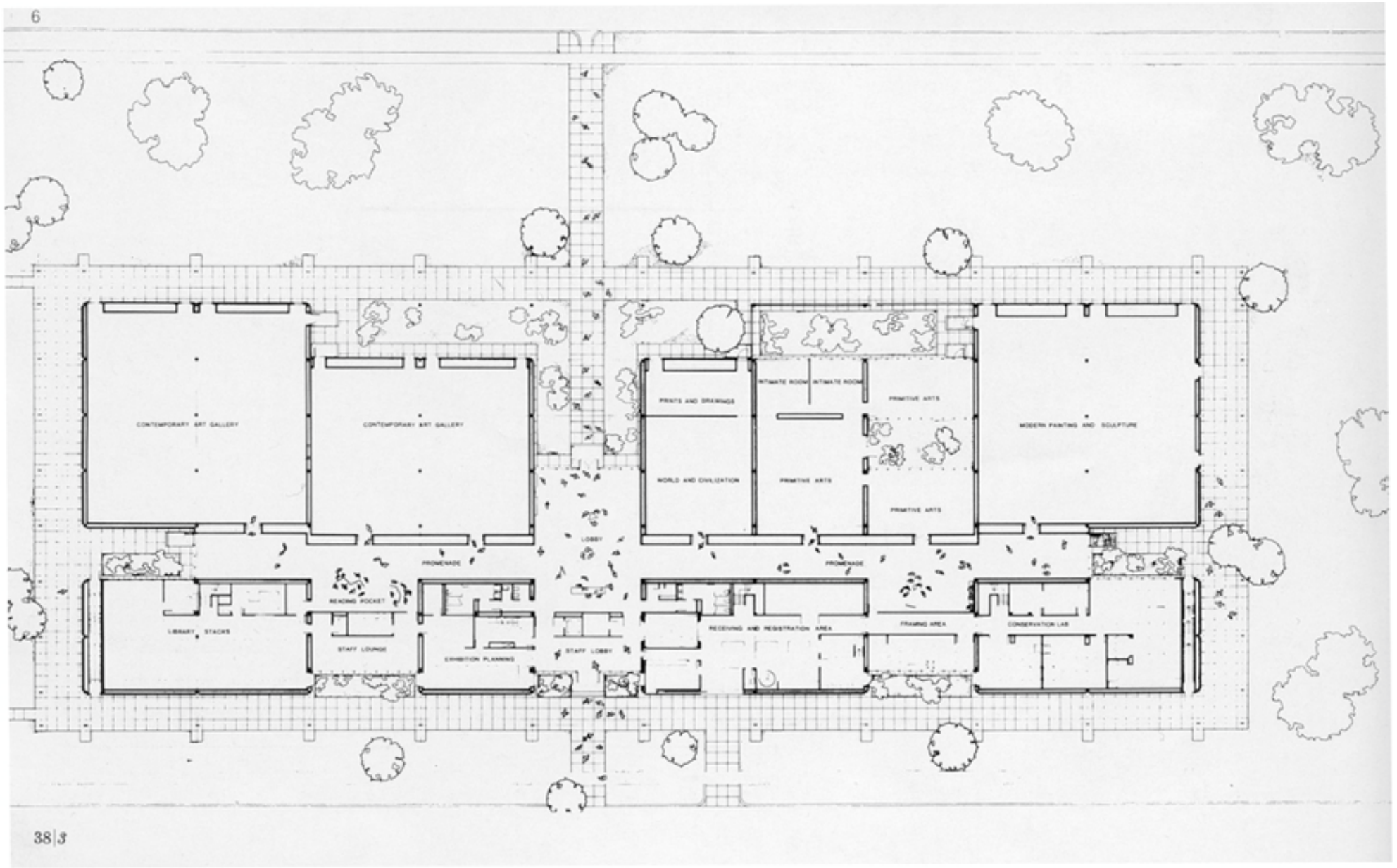

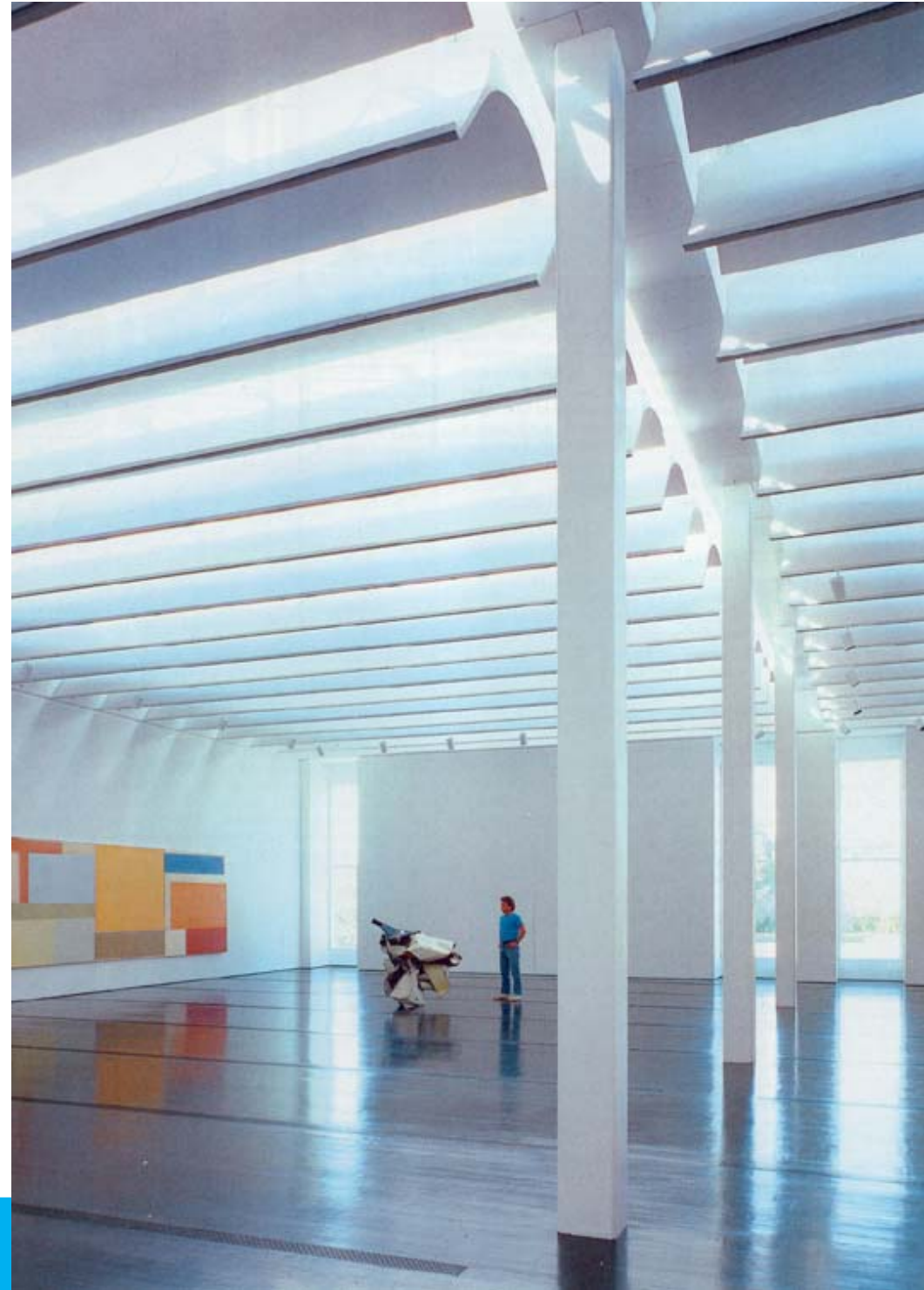



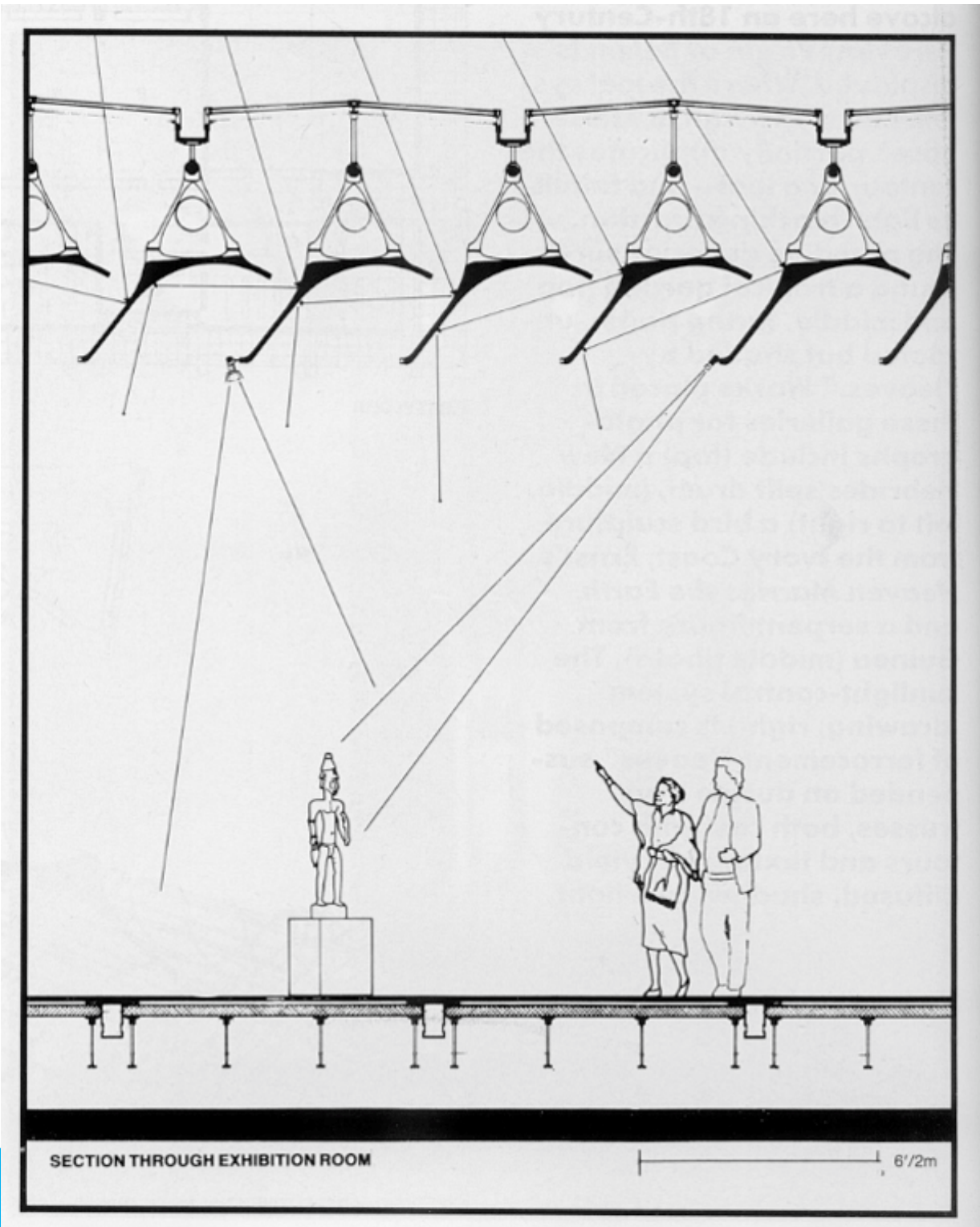

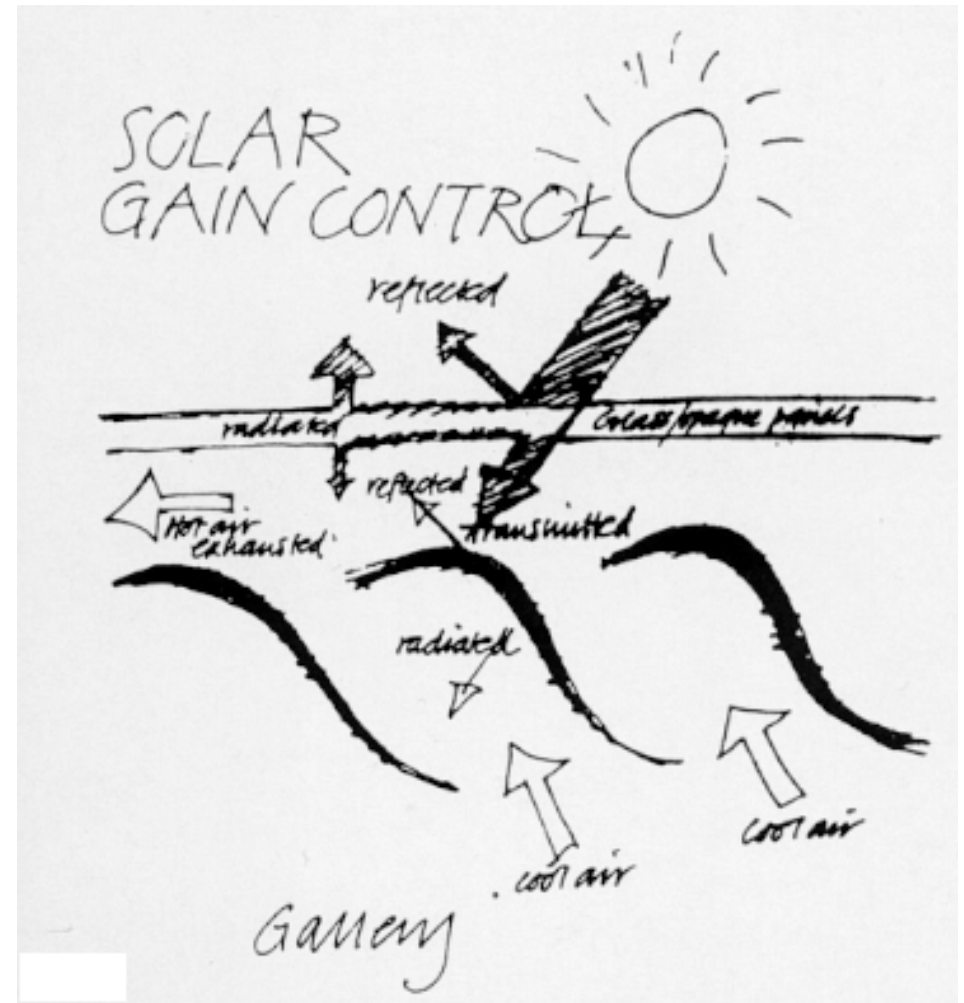
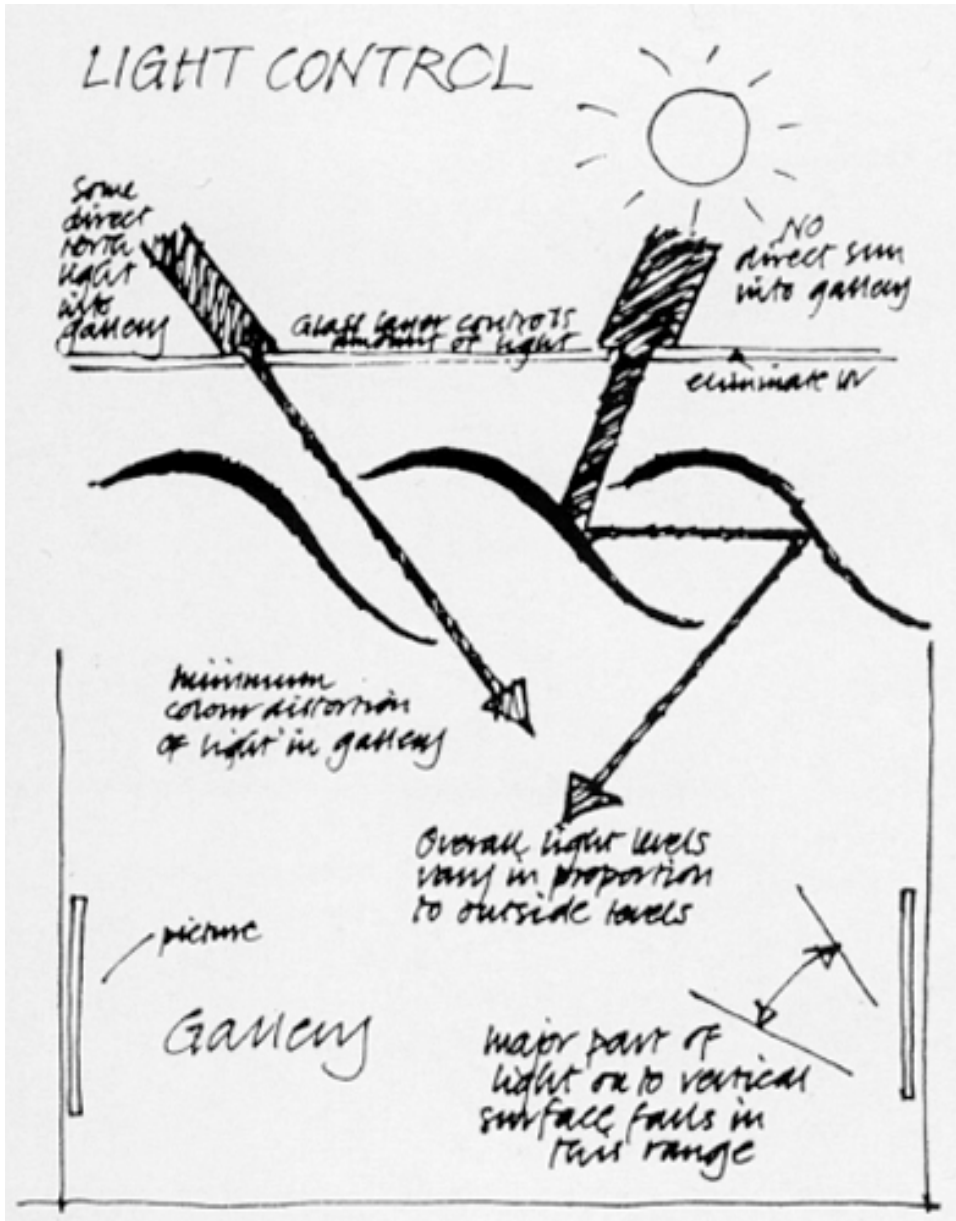

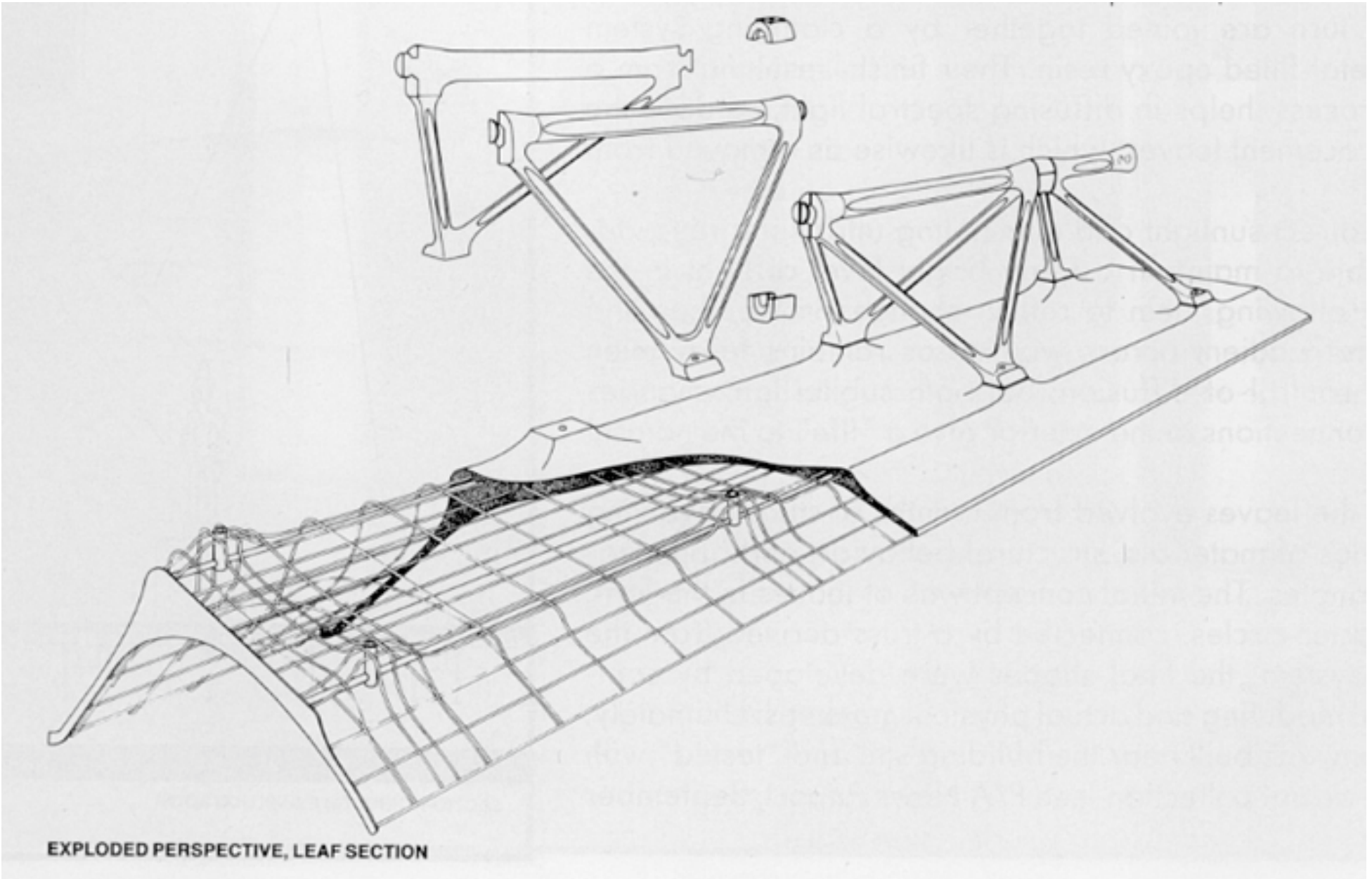

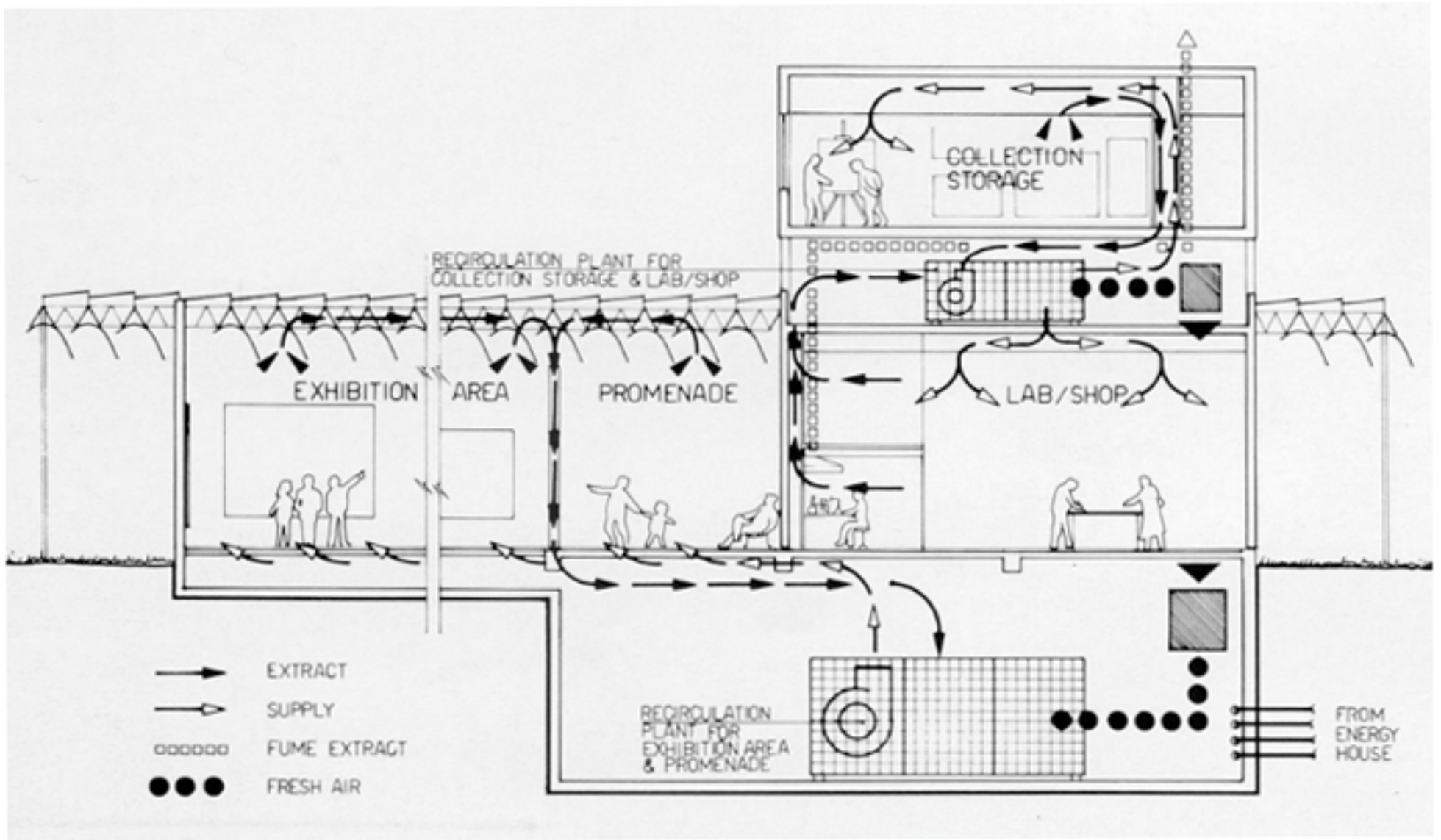

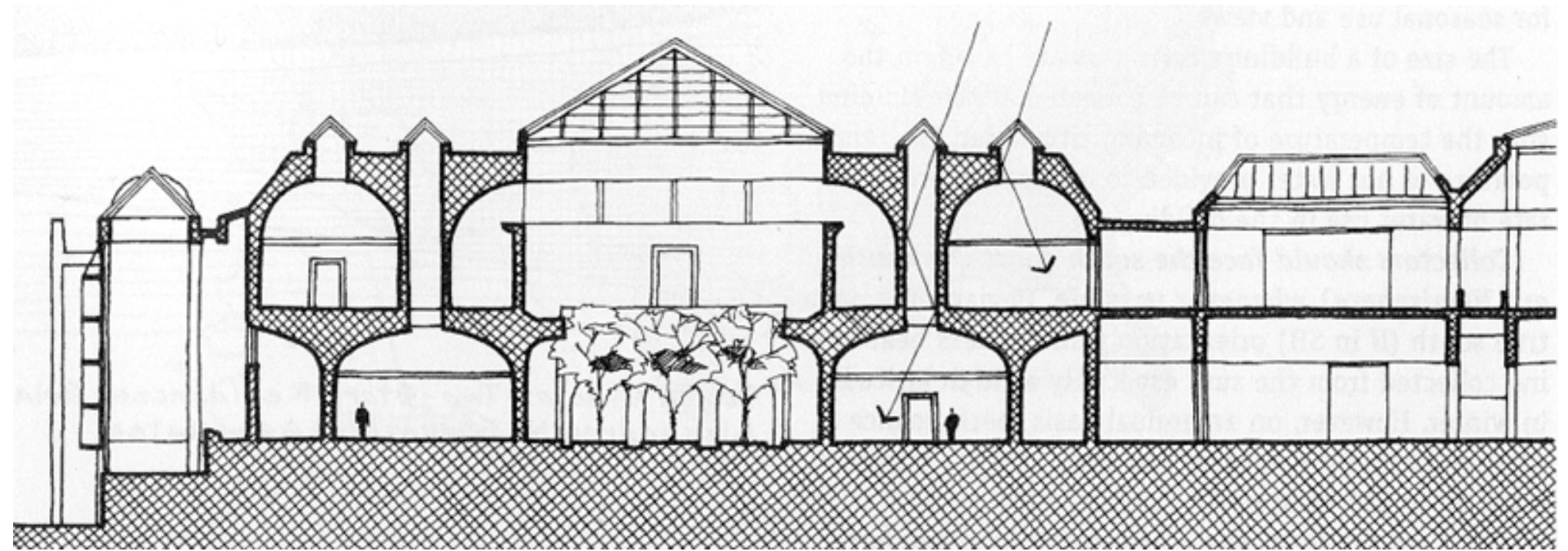

Lightwells in the National Gallery of Canada, Moshe Safdie



Arch 226: Environmental Building Design



Arch 226: Environmental Building Design

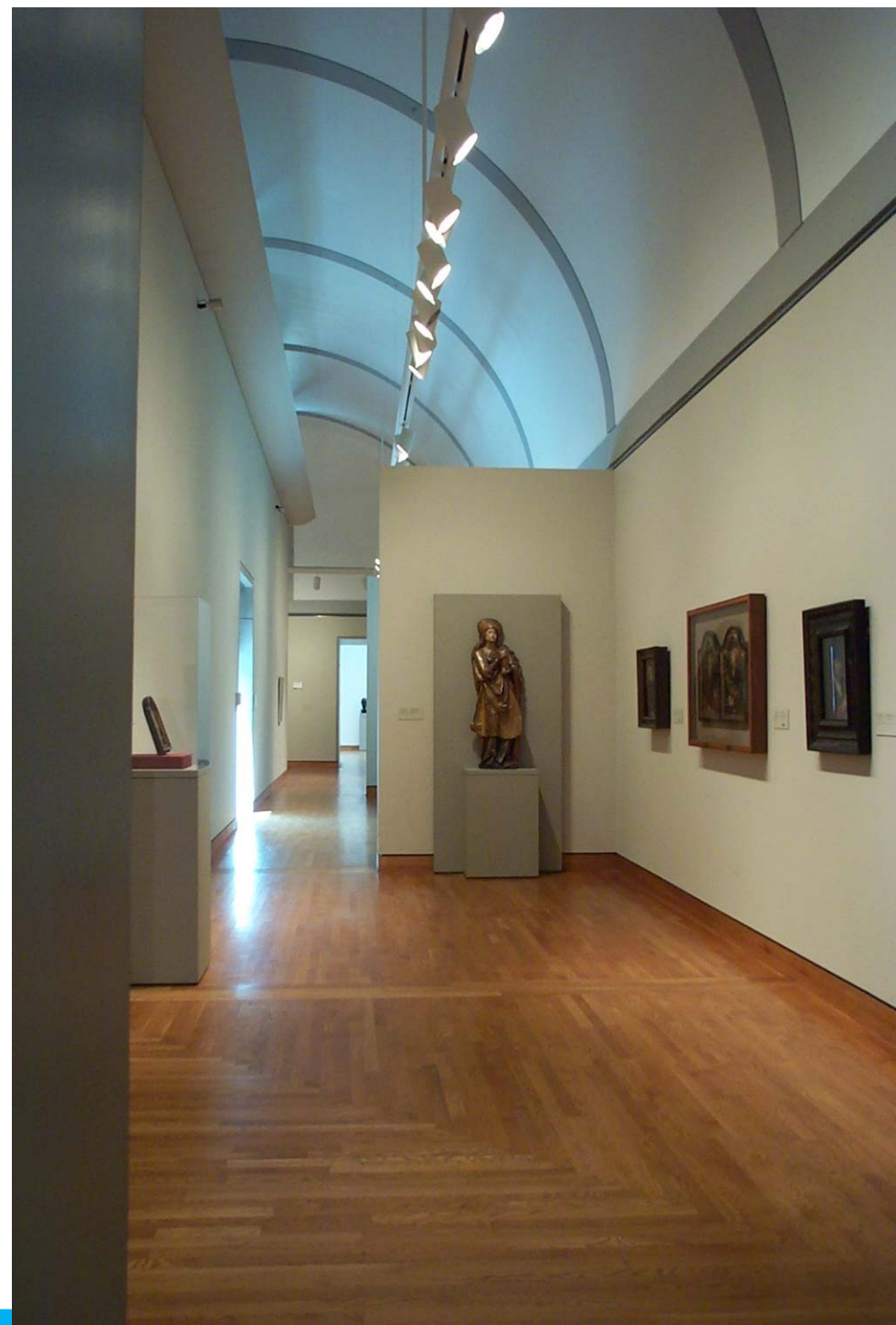

Arch 226: Environmental Building Design